

Off-road Rubber Track Carrier

BFP602

Operator's Manual

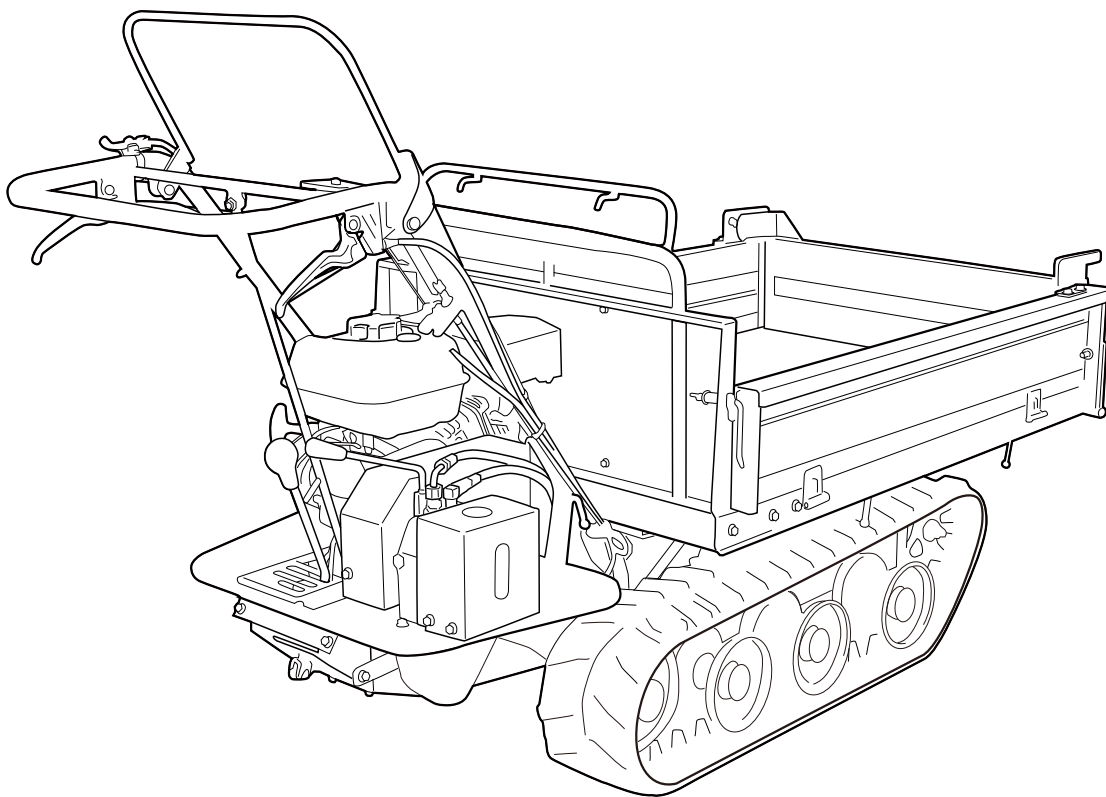

⚠ WARNING!

Read this manual completely before operating or maintaining this machine.
Failure to follow safety precautions could result in serious injury or death.
Keep this manual for future reference by you and by all those who operate
and maintain this machine.

3526 5704 000

CHIKUSUI CANYCOM, INC.

90-1 Fukumasu, Yoshii-machi,

Ukiha-shi, Fukuoka, Japan 839-1396

Tel.+81-(0)943-75-2195 Fax.+81-(0)943-75-4396

Notice to Users and Maintenance Personnel

Thank you for purchasing this machine.

This manual provides information needed for safe and effective use of this machine to those who operate or maintain this machine. Make sure to read and understand this manual thoroughly before operating this product. Also make sure to read the separate operator's manual for the engine.

WARNING!

- **This machine can be very dangerous if the safety precautions in this manual and on labels attached to this machine are not followed. Read and understand this manual and safety labels on machine thoroughly before using this machine. Always follow the instructions and safety precautions, or serious injury or death could result.**
- **This machine should only be used for its intended purpose: hauling and dumping. Any other use could be dangerous.**
- **This machine may not be operated on public road or what is considered to be public road. It is the sole responsibility of the operator to consult the local regulations.**
- **Do not modify this machine, or do not operate this machine with safety covers removed or open. A serious accident could result.**

CAUTION!

- **Store this manual in a safe, accessible place for easy reference.**
-



Notice to Owner

CAUTION!

- Be sure that everyone who uses this machine, including those who rent or lease this machine, receives a copy of this Operator's Manual and understands the importance of reading and following the information in this manual.

Warning Terms Used in this Manual

In this manual, the following four warning terms are used to signal the four levels of hazard (or seriousness of possible accidents). Read and understand what they mean and always follow the instructions in this manual.

Warning Term	Definition
 DANGER!	Indicates an imminently hazardous situation which will result in death or serious injury if the user does not follow the procedures or the instructions.
 WARNING!	Indicates a potentially hazardous situation which could result in death or serious injury if the user does not follow the procedures or the instructions.
 CAUTION!	Indicates a potentially hazardous situation which could result in minor to moderate injury or damage to the machine if the user does not follow the procedures or the instructions.
<u>NOTE</u>	Indicates important information which needs particular attention.

Warranty and After-Sales Service

Warranty

CHIKUSUI CANYCOM, INC. provides you a warranty through Canycom U.S.A. A copy of this warranty is reproduced in the back of the manual.

After-Sales Service

Consult your local CANYCOM dealer or our company's sales department regarding service orders or any questions or problems that may arise when using this machine. Please make sure to have the product name, serial number, and the make and type of engine handy at the time of contact. The model and serial number can be found on the model label as shown below, and the make and type of engine can be found in Chapter 3 "**Specifications**" of this manual (Page10).

Location of Model Label

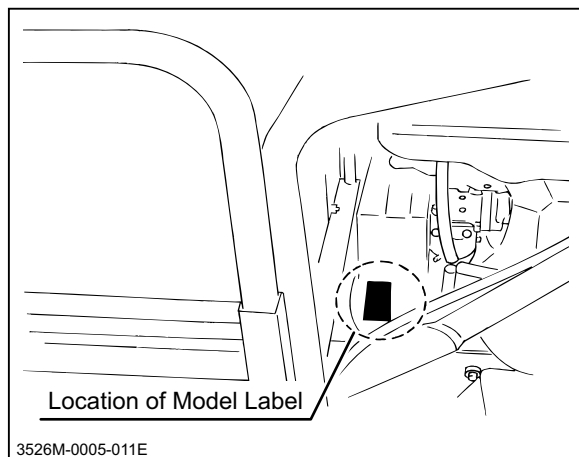

Model Label



3526M-0005-021E

Availability of Spare Parts

The replacement or repair parts for this product shall remain available for seven years after the production of this type of machine is discontinued.

Emission Control Information

Emission Control Information

This product meets the applicable emissions and evaporative regulations as required by the United States Environmental Protection Agency or the California Air Resources Board. The relevant information is provided in the label shown below.

Location of Emissions Label

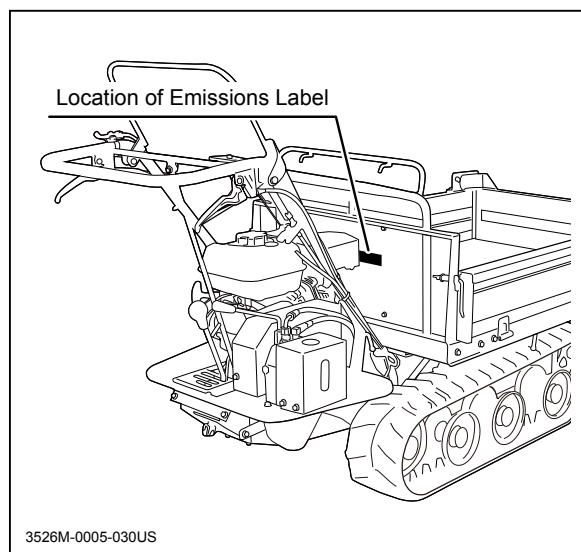

Emissions Label

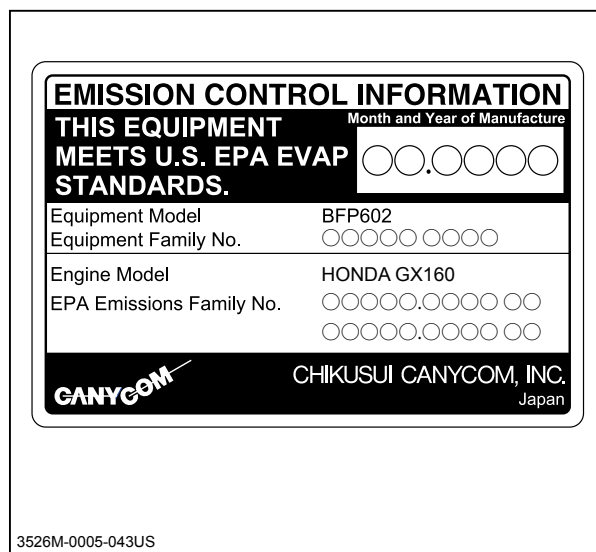

Sample label shown. Emission control information is subject to change each model year. Please refer to the actual emissions label on the machine for details.

Contents

1. Safety	1
Safety Labels	1
Safety Precautions	2
Training	2
Preparation	3
Operation	3
Servicing	8
2. Controls and Components	9
Name and Function of Controls	9
3. Specifications	10
Product Specifications	10
Contents of the Tool Bag	11
4. Operation	12
Preparation	12
Pre-start up Inspection	12
Checking and Filling Fuel	12
Driving	13
Starting	13
Driving	16
Stopping	19
Shifting	20
Parking	21
Working	23
Dumping	23
Using Safety Prop.	24

5. Maintenance 25

Maintenance Schedule	25
List of Fluids and Lubricants	30
List of Consumables and Spares	31
Engine	32
Engine Oil	32
Air Cleaner Element	33
Spark Plug	33
Fuel Cock (Fuel Filter)	34
Drive Train	35
Track	35
Transmission Oil	36
V - Belt	37
Belt Stopper	38
Brake	38
Drive Clutch	39
Side Clutch	39
Lubrication	40
Hydraulic System (Hydraulic Dump Model)	41
Hydraulic Package	41
Hydraulics Belt	42
After Use Care	43
After Normal Use	43
After Cold Weather Use	43
Storage	44

6. Troubleshooting 45

Troubleshooting	45
----------------------------------	-----------

7. Transporting 49

Hauling	49
Loading and Unloading	49

Warranty

Warranty Certificate is attached at the end of this manual.

- * Have the warranty certificate signed and sealed after you have received and fully understood the instructions for handling this machine and received the receipt.

Appendix

- Operator's Manual for the Engine
 - * Be sure to read and understand it together with this manual .
-

Safety Labels

The safety labels shown below are attached to the machine. See the illustration for the location and the content of each label on the machine.

- **Locate all the warning labels attached to this machine. Read and follow the instructions and precautions in them. Failure to do so could result in serious injury or death to the operator or bystanders.**
- **Keep the labels clean and legible. Do not use solvents or gasoline to clean the labels.**
- **Replace these labels immediately if they have been removed, have fallen off or become illegible. Use the part number, on the label or shown in this manual, to order a replacement label from your CANYCOM representative.**

Three-way Folding Gate Model

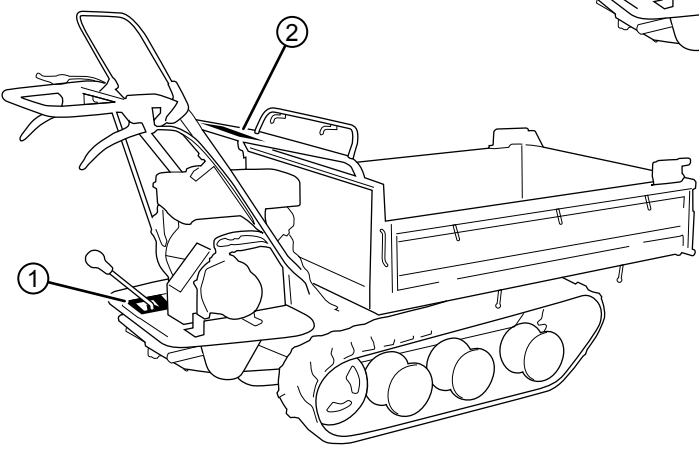



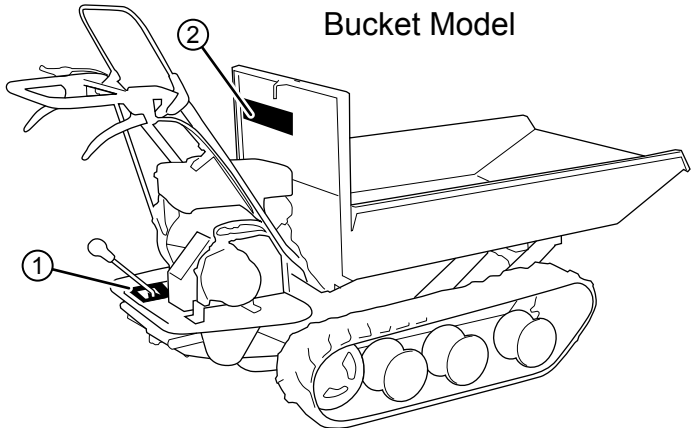

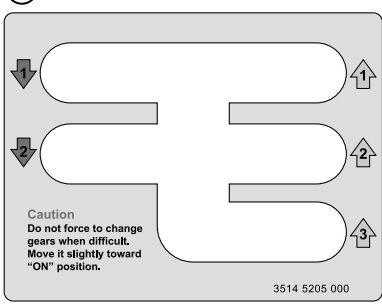

Bucket Model



① 3514 5205 000



② 3573 6061 000

 ▲WARNING! Read and FULLY understand the operator's manual before use or maintenance.	 ▲WARNING! Moving belts can entangle hand and arm. Keep hands away to avoid injury.	 ▲WARNING! Crush hazard. Beware of obstacles when reversing or turning. Always operate slowly and keep two meter or more clearance.	 ▲WARNING! Always shift gears firmly, or it can jump out of gear, resulting in loss of control and death or serious injury.	 ▲DANGER! Never operate on a slope steeper than the gradeability angle. Observe load limit when operating on a slope below that angle.	 ▲DANGER! Distribute load evenly and fix it securely. Un-balanced or loose load can cause tip-over.	 ▲DANGER! Crush hazard. To prevent death or serious injury do NOT place any part of your body under the loading deck.
---	---	---	---	---	---	---

3526M-0101-012US

Safety Precautions

This section contains safety precautions to follow when operating and maintaining machine. Read and understand the precautions in this section as well as throughout this manual and follow them when operating or maintaining machine. Failure to follow safety precautions could result in property damage, serious injury or death to the operator or bystanders.

Training

All operators should be familiar with the following issues when using this machine. In case machine is used by a hired worker or is rented, the employer or renter shall give practical instructions covering the following issues to the user.

- **It is essential to familiarize yourself with controls, safety labels and the proper use of machine.**
- **Never allow people unfamiliar with these instructions to operate or service machine. Do not let anyone under 18 years of age to operate this machine. Local regulations may restrict the minimum age for operating a machine. Consult your local authority.**
- **This machine is not intended to carry a person. Do not ride or carry a person.**
- **The operator is responsible for the accidents or hazards caused to other people or their property.**
- **Always keep in mind that care and concentration is required when working with a load-carrying machine.**
- **Loss of control on a slope cannot be regained by the application of brake. Main reasons for the loss of control are:**
 - **insufficient grip of tracks.**
 - **excessive speed.**
 - **misjudging of the ground conditions, especially inclination.**
 - **excessive load.**
 - **incorrect distribution of load.**

Preparation

- **Always wear protective footwear, long trousers, hardhat, safety glasses and ear protection when operating or servicing machine. Proper clothing will minimize the chance of injury. Do not operate machine if you have long hair, loose clothing, or jewelry; all of which can get tangled in moving parts. Do not operate machine barefoot or with open sandals.**
- **Prepare beforehand the working rules and procedures such as signaling and traffic control for the work place. Following such rules will reduce the risk of accidents.**
- **Perform daily pre-startup inspection (see Preparation, page 12) before starting machine. Repair or replace damaged parts before starting machine.**
- **Fuel is highly flammable. See Checking and Filling Fuel, page 12, for important safety information on handling fuel; keep fire and spark away. Stop engine when refueling.**
- **Never handle oil or grease, service engine, or recharge battery in the presence of fire or spark.**

Operation

This machine is intended for carrying grains, produce, dirt and similar materials. Carrying other objects may damage machine. Avoid carrying liquid concrete. That will damage machine.

The stability of machine is affected by speed, rate of steering, terrain and load. Always pay close attention to these factors or loss of control or tipping over could occur, resulting in property damage, serious injury or death.

General Driving

- Do not operate engine in a confined space where dangerous carbon monoxide fumes can accumulate.
- Do not touch engine, muffler or exhaust pipe while engine is running or soon after it has stopped. These areas will be very hot and can cause burns.
- Do not operate machine under the influence of alcohol or drugs. Do not operate machine when you are tired, ill, or not fit to operate machine.
- Before starting engine and moving machine, scan around your surroundings and make sure all persons and other vehicles are a safe distance away from machine.
- Never operate on terrain that you are not comfortable with. Avoid terrain that is so rough, slippery or loose that you feel like machine could tip over.
- Always check for obstacles before operating on new terrain.
- Always travel slowly and use extra caution when operating on unfamiliar terrain. Be alert when traveling on changing terrain.
- Set handle lever to fit the operator's physique. Always hold handle grips with both hands to keep a posture when operating machine.
- Drive at a safe speed, taking into account surface gradient, surface conditions and load.
- Do not make sudden maneuvers. Sudden start, stop, or turn can make machine lose control and could cause a tip over. Be especially cautious when traveling on soft or wet ground.
- Never drive machine with its loading deck in lifted or raised position. Make certain that loading deck is in the lowest and locked position when driving.

- On a slippery surface, travel slowly and exercise caution to reduce the chance of skidding or sliding out of control. Never operate on ice.
- Always make certain that there is no obstacle or person behind machine when backing up. Make certain that it is safe to back up, then move slowly and avoid sharp turns.
- To reduce the risk of tipping over, pay special attention when encountering an obstacle or a slope, or when braking on a slope or during a turn. See Driving on a slope below.
- Never attempt to drive over a large obstacle such as rock or fallen tree.
- Do not operate machine near the edge of a cliff, an overhang or a landslide area.
- Use an observer to help direct machine when visibility is poor, terrain is rugged or hilly, or maneuvering room is limited. An observer should be able to see machine and its immediate surroundings, and should give pre-arranged signals to direct the operator.

Driving on a Slope

- Driving on a slope can be dangerous. It can result in a tip over and cause serious injury or death. Always follow proper procedures for driving on a slope as described in this manual.
- When carrying no load, do NOT use machine on a slope steeper than 25 degrees. When carrying a load, observe the load limit according to the inclination (see Loading and Driving with the Load, page 7). Do not lift or dump on a slope.
- Driving on a slope in a wrong manner can cause a loss of control or a vehicle tip over. Check terrain carefully before attempting to drive on a slope.

- **Never drive on a slope that you are not comfortable with. Avoid a slope that is so rough, slippery, or loose that you feel like machine could tip over.**
- **When driving down a slope, stop and shift to one of the first three gears (auxiliary transmission in Low). Go down at a reduced speed. Use engine speed to help keep machine speed low.**
- **When driving up a slope, proceed at a steady rate of speed and throttle position.**
- **Never move throttle lever or operate side clutch suddenly.**
- **Drive straight up or down a slope. Avoid turning on a slope. Avoid driving machine across a slope.**
- **If engine stalls or loses traction during a climb and cannot make it to the top of a slope, do not try to turn machine around. Carefully back down slowly, straight down a slope.**
- **When going over the top of a slope, go slow; an obstacle, a sharp drop, or another vehicle or person could be on the other side of the crest.**
- **Without a load, drive machine backwards up a slope (operator's handle toward the top) when climbing, and drive it forward when going down a slope.**
- **With a load, drive machine forward up a slope (operator's handle away from the top) when climbing, and drive it backwards when going down a slope. Be especially cautious when operating on a slope with a load.**

Loading and Driving with a Load

- **The maximum payload for this machine is 450kg. Do not exceed this maximum payload under any circumstance.**
- **Do not operate on a slope steeper than 20 degrees when carrying a load. Do not carry more than 225kg when operating on a slope between 15 and 20 degrees.**
- **Place a load in loading deck so that the weight is evenly distributed. When carrying a load, strap it to loading deck to prevent it from shifting. Ensure that the load does not obstruct the operator's field of view.**
- **When carrying a load, drive at a reduced speed. Allow greater distance for braking.**
- **Before crossing a bridge or an overpass, make certain that the total combined weight of machine, load and operator is within the stated weight limit of the bridge or the overpass. Then, proceed carefully and at a constant speed.**

Lifting and Dumping

When lifting or dumping material from loading deck, take the following precautions.

- **Always follow the proper procedures for lifting and dumping as described in this manual.**
- **Perform lifting or dumping operation on a flat, level and stable surface. Do not lift or dump on a slope or on a rough terrain.**
- **Make certain that all persons are at a safe distance away from machine when lifting, raising or lowering loading deck.**
- **Do not move machine or leave it unattended with loading deck in the lifted or raised position.**
- **Engage loading deck lock plate if you must place any part of your body under loading deck in the lifted position. Never place any part of your body under loading deck in the raised (dump) position.**

Parking

- Park machine on a flat, level and stable surface. Do not park in a dangerous place. Never park machine on a slope steeper than 15 degrees. Avoid parking on a slope less than 15 degrees. If parking on a slope less than 15 degrees is unavoidable, block tracks at the lower end of machine.
 - Without a load, park machine with operator's handle uphill
 - With a load, park machine with operator's handle downhill
 - Do not park sideways on a slope.
- Observe all the previous precautions for general driving, riding machine, driving on a slope, loading and driving with a load, and dumping.
- Whenever you park machine, disengage clutch and stop engine.
- Gasoline is highly flammable and can be explosive. When parking machine indoors, make certain that the building is well ventilated and that machine is not close to any source of flame or spark, including appliances with pilot lights.

Servicing

- Do not service machine when engine is running. If it is absolutely necessary to run engine while servicing, keep hands, feet, clothing and any part of the body away from any moving part, especially belts at the side of engine.
- Do not operate engine in a confined space where dangerous carbon monoxide fumes can accumulate.
- Engage loading deck lock plate if you must place any part of your body under loading deck in the lifted position. Never place any part of your body under loading deck in the raised (dump) position.
- Check all fuel lines on a regular basis for fit and wear. Tighten or repair them as needed.
- Do not touch engine, muffler, or exhaust pipe while engine is running or soon after it has stopped. These areas will be very hot and can cause burns.
- Engine must be shut off before checking or adding oil.

Name and Function of Controls

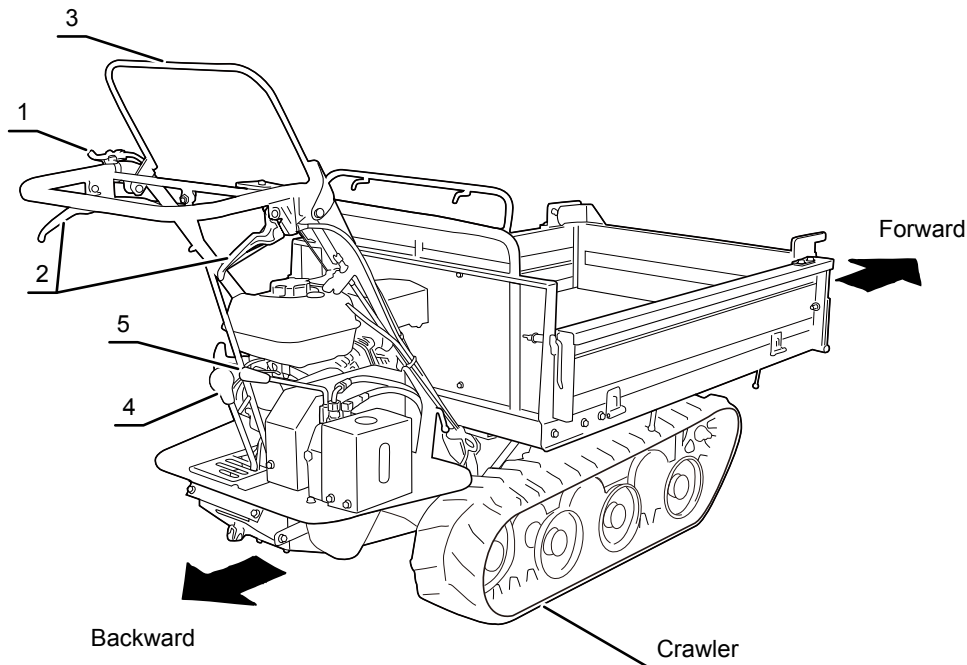

3526M-0201-010US

- 1 Throttle Lever** Throttle Lever is used to control engine speed.
- 2 Side Clutch Lever** Side Clutch Lever is used to steer machine by engaging side clutch. Machine stops when both of the levers are hold together.
- 3 Drive Clutch Lever** Drive Clutch Lever is used to engage or disengage drive clutch.
- 4 Shift Lever.** Use for selecting the drive speed. Shift the transmission during the machine stops with drive clutch lever is off.
- 5 Dump Lever** Used to dump the loading deck hydraulically.
(Hydraulic Dump Model)

Product Specifications

⚠ CAUTION!

· Use this product properly after understanding its specifications thoroughly.

Model and Type			BFP602		
			Flat-Bed	Scoop Bucket	
Machine Mass		kg (lbs)	205 (452)	225 (496)	
Maximum Payload		kN (lbs)	4.41(992)		
Dimensions	Overall Length		mm (in)	1900 (74.80)	1980 (77.95)
	Overall Width		mm (in)	840 (33.07)	780 (30.71)
	Overall Height		mm (in)	960 (37.79)	
	Track Contact Length		mm (in)	675 (26.57)	
	Track Tread		mm (in)	540 (21.26)	
	Track Width		mm (in)	180 (7.09)	
	Ground Clearance		mm (in)	110 (4.33)	
Loading Deck	Loading Deck Height		mm (in)	400 (16.53)	450 (17.72)
	Inside Dimensions	Length	mm (in)	1050 (41.34)	1190 (46.85)
		Width	mm (in)	745 (29.33)	735 (28.94)
Height		mm (in)	185 (7.28)	200 (7.87)	
Engine	Model		Honda GX160		
	Type		4-stroke overhead valve single cylinder		
	Cylinder (Bore×Stroke)		mm (in)	68×45(2.7×1.8)	
	Displacement		cm ³ (cu. in)	163(9.9)	
	Net Power		kw(PS)/rpm	3.6/3600 (4.9/3600)	
	Continuous Rated Output		kw(PS)/rpm	2.9/3600 (3.9/3600)	
	Max.Net Torque		N•m(kgf•m)/rpm	10.3/2500 (1.05/2500)	
	Starter System		Recoil		
	Fuel		Automotive Unleaded Gasoline		
	Fuel Consumption		L/h	1.4	
	Fuel Tank Capacity		L (US Gal)	3.1(0.82)	
Oil Capacity		L (US qt)	0.58 (0.61)		

Model and Type				BFP602	
				Flat-Bed	Scoop Bucket
Performance	Speed	Forward 1st	km/h (mph)	1.7 (1.1)	
		Forward 2nd	km/h (mph)	3.5 (2.2)	
		Forward 3rd	km/h (mph)	5.4 (3.4)	
		Reverse 1st	km/h (mph)	1.6 (1.0)	
		Reverse 2nd	km/h (mph)	3.2 (2.0)	
	Minimum Turning Radius		m (ft)	1.2 (3.93)	1.21 (3.97)
Gradeability		Degrees	25 (unloaded) / 15 (with max. load)		
Drivetrain	Clutch		Belt Tension		
	Main Transmission		Gear Slide		
	Steering Mechanism		Dog Clutch /		
	Brake		Internally Expanding		
	Transmission Oil Capacity		L (USqt)	1.5 (1.59)	
Deck	Dump System		Hydraulic		
	Dump Angle		Degrees	58	

*These specifications are subject to change without notice.

Contents of the Tool Bag

No.	Content	Quantity	Note
1	Operator's Manual	1	This Manual
2	Operator's Manual for the Engine	1	
3	Engine Service Tool	1	for Servicing the Engine

Preparation

Pre-start up Inspection

Always perform an inspection before use.

Refer to "**Maintenance Schedule**" (page 25) for the inspection schedule and procedure.

Checking and Filling Fuel

⚠ WARNING!

- Keep fire and spark away when handling fuel.
- Always stop engine before refueling.
- Keep the fuel level below the bottom of fuel filter inside fuel filler. Do not overfill fuel so that fuel will not overflow. In case fuel is spilt, wipe out immediately.

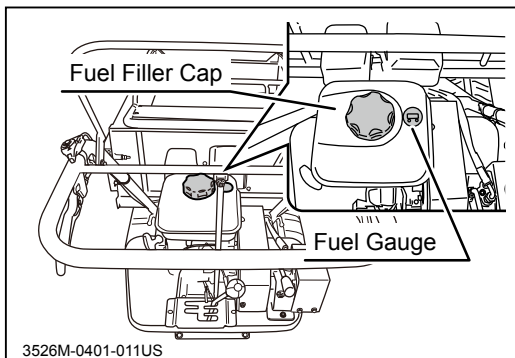

1. Check fuel gauge. If fuel level is low, fill fuel.
2. Open fuel filler cap and fill fuel.
3. Close fuel filler cap securely.

NOTE

- Fuel : Automotive Unleaded Gasoline
- Fuel Tank Capacity: 3.6 L (0.95 US gal)

Driving

Starting

⚠ WARNING!

- Always start and run engine in a well ventilated place.
- Always make certain of the safety of your surroundings when starting engine.

⚠ CAUTION!

- Do not use this machine in temperatures above 40°C (104°F) or below -15°C (5°F). This machine cannot perform adequately in these temperature ranges. Using this machine under such conditions may result in an accident or cause damage to machine.
- In the winter or cold climate, warm up engine thoroughly before driving machine. A cold engine delivers poor performance, which may result in an accident. It also causes excessive wear.
- Do not use this machine in dusty places such as desert. Dust may clog air cleaner or enter engine, which may result in loss of performance and an accident. It also causes excessive wear.
- Do not use this machine in the altitude above 1500m (4921ft) in its original configuration. This machine cannot perform adequately above that altitude. Using this machine under such conditions may result in an accident or cause damage to machine. If you need to use this machine above that altitude, contact your Canycom representative.

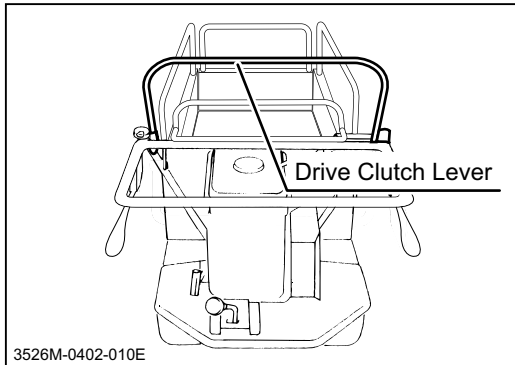

1. Make sure drive clutch lever is in [Stop] position.

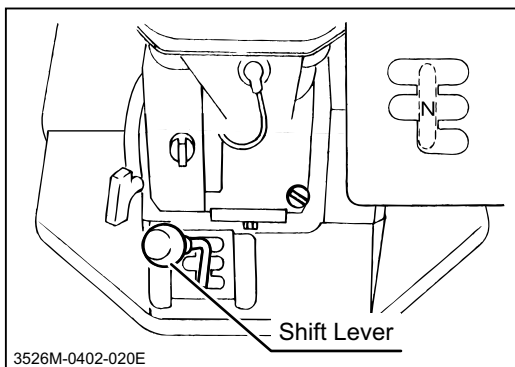

2. Make sure shift lever is in [N (neutral)] position.

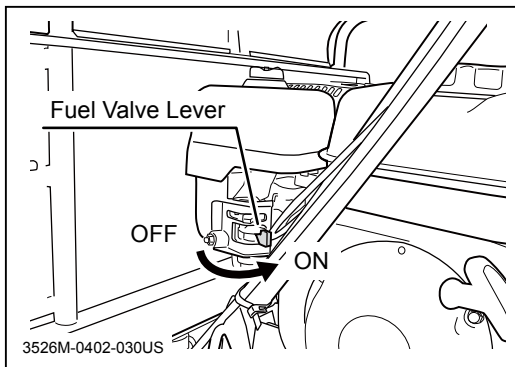

3. Turn the fuel valve lever [ON].

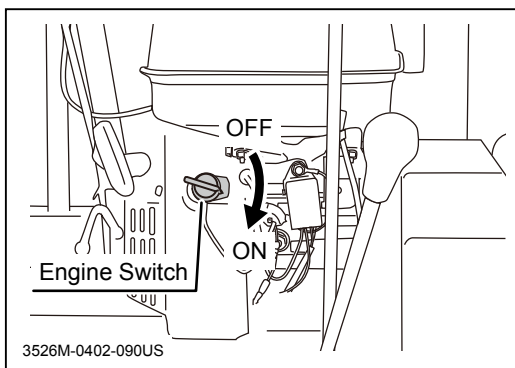

4. Turn the engine switch [ON].

NOTE

- See the Engine Manual about engine switch.

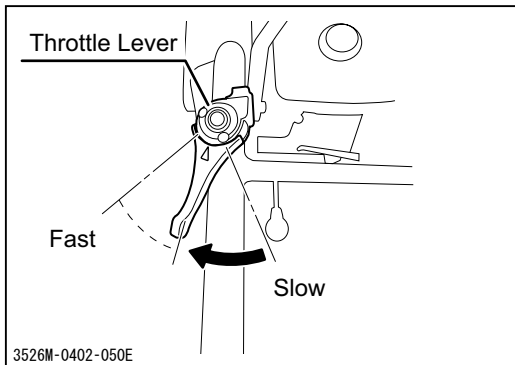

5. Move throttle lever in between [Slow] and [Fast] positions.

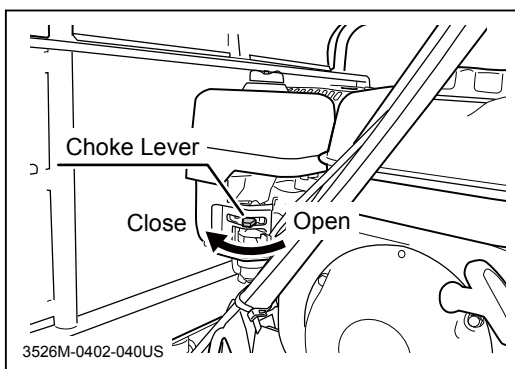

6. Move choke lever to [Close ()] position.

NOTE

- When engine is warm, it is not necessary to move choke lever to the close position.
- See the Engine Manual about the choke lever.

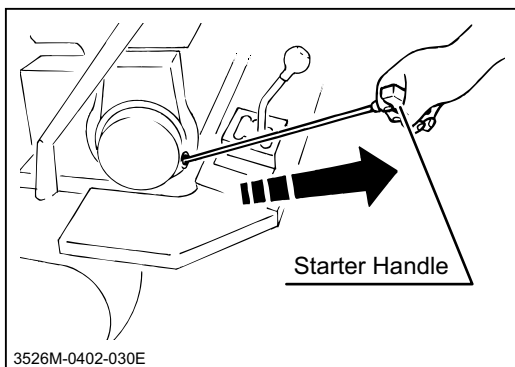

7. Pull starter handle rapidly to start engine. When engine starts, return handle gently.

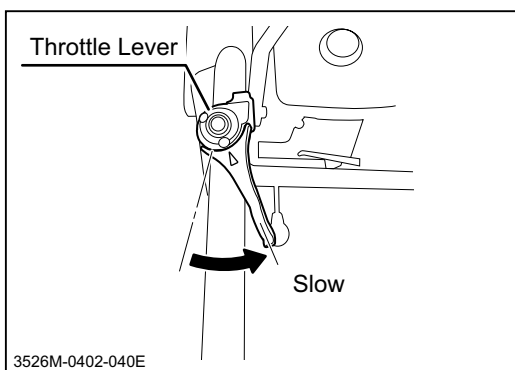

8. Move throttle lever to [Slow] position after engine starts.

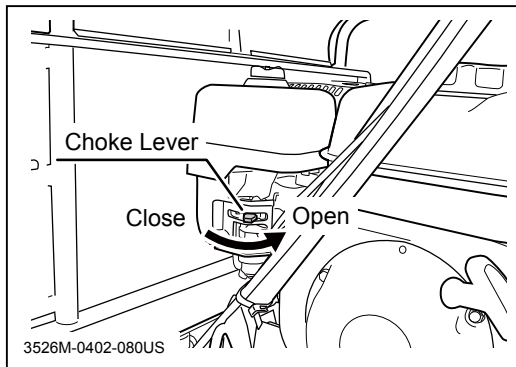

9. Move choke lever back to the [Open (| |)] position and run engine for about 5 minutes without load to warm up.

NOTE

- Drive machine gently in the first 40 to 50 hours of use after purchase for breaking-in.

Driving

⚠ WARNING!

- Do not allow bystanders to come near machine when driving.
- Always make certain of the safety of your surroundings before driving; start slow. Adjust speed according to the condition and gradient of the surface on which you are traveling.
- Do not make sudden start, acceleration, change of speed, change of direction, or stop. Do not turn at high speed. Avoid sudden maneuvers; this may cause the operator to be dragged or to be thrown, or machine to tip over.
- Never drive machine with its loading deck in lifted or raised position. Make certain that loading deck is in the lowest and locked position when driving.
- Shift transmission in low gear and drive slowly when traveling on a slope. Operator can be dragged or thrown, or machine can tip over.
- Do not drive machine across a slope. Machine can slip or tip over.
- Do not turn on a slope. Machine can turn the opposite direction, slip or tip over.
- Use an observer to help direct machine when the visibility is poor, terrain is rugged or hilly, or maneuvering room is limited. The observer should be able to see machine and its immediate surroundings, and should give pre-arranged signals to direct the operator.

⚠ CAUTION!

- Pinch hazard. Make certain that hands or fingers are not in the way to be caught when operating clutch lever.

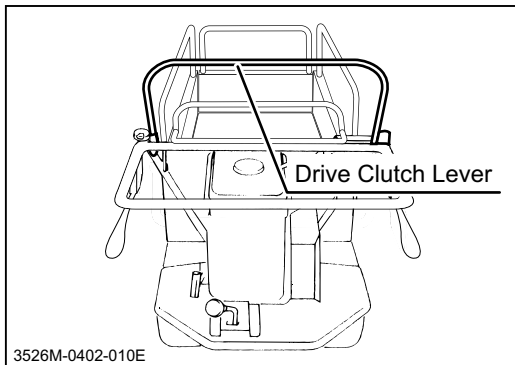

1. Make certain of the safety of your surroundings.
2. Make certain that drive clutch lever is in [Stop] position.

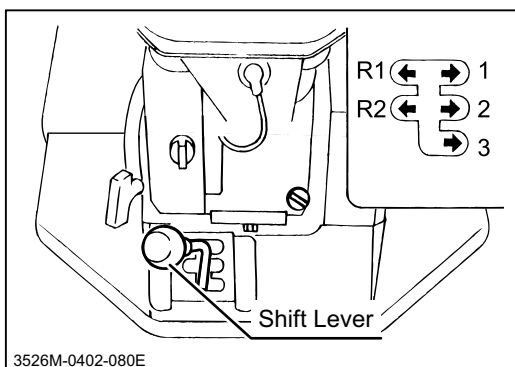

3. Move shift lever into a desired position.

NOTE

- Refer to "Product Specifications" (Page 10) for speed in each gear.
- When it is difficult to shift gears, move drive clutch lever toward [Run] position slightly and try again. It may help shifting smoothly.

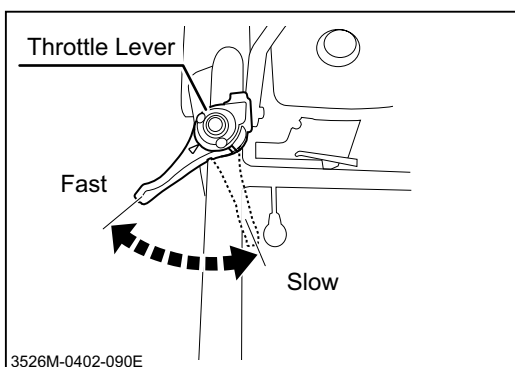

4. Move throttle lever gradually to [Fast] position to raise engine speed.

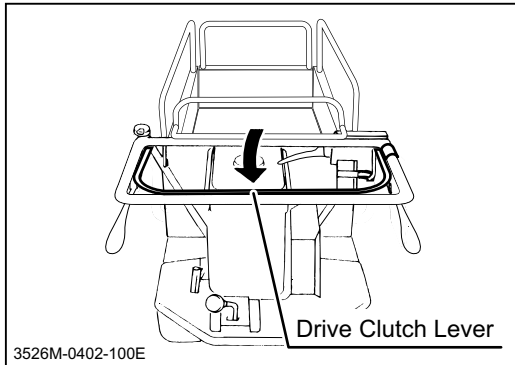

5. Move drive clutch lever gently to [Run] position to start.

NOTE

- Sudden lowering the drive clutch lever may cause engine to stall.

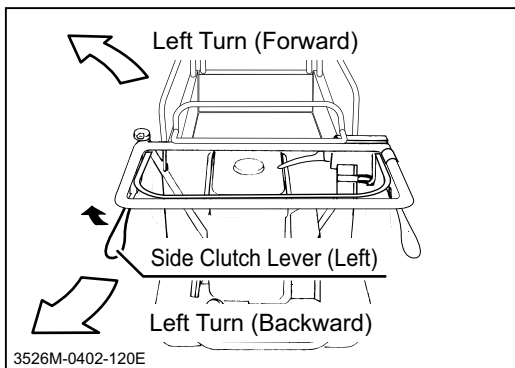

6. Grasp left side clutch lever to turn left.

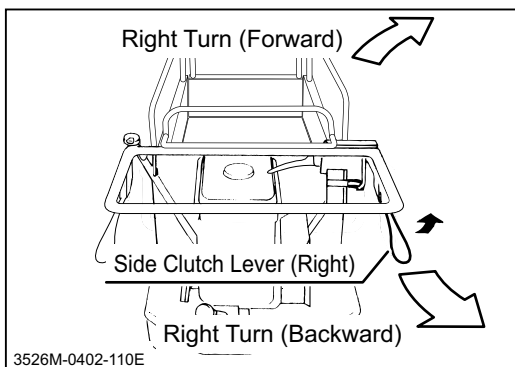

7. Grasp right side clutch lever to turn right.

Stopping

⚠ WARNING!

- Do not make a sudden stop. The machine may skid or tip over.
- Always park on a firm, level place. Never park on a potentially dangerous place.

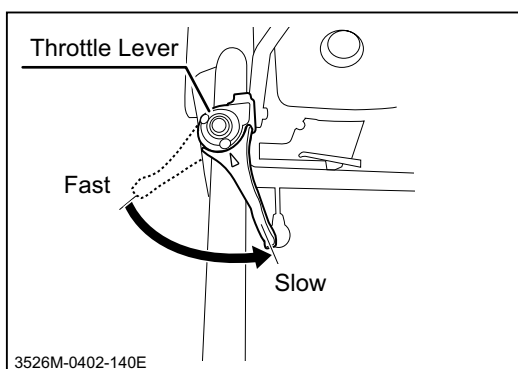

1. Move throttle lever toward [Slow] position to slow down.

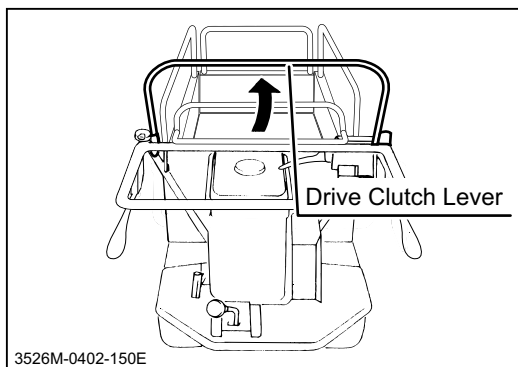

2. Move drive clutch lever to [Stop] position to stop.

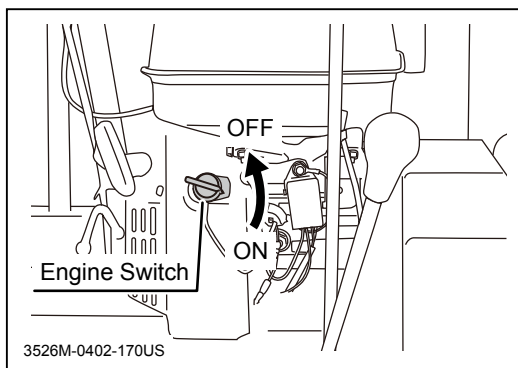

3. Turn the engine switch [OFF].

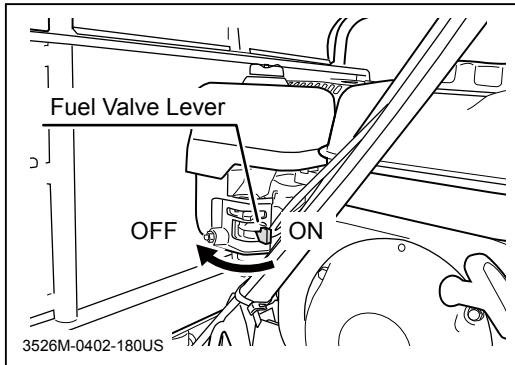

4. Turn the fuel valve lever [OFF].

Shifting

⚠ WARNING!

- Always stop machine to shift gears.
- Always shift gears firmly. When transmission is not firmly shifted, it may jump out of gear, resulting in loss of control of machine.

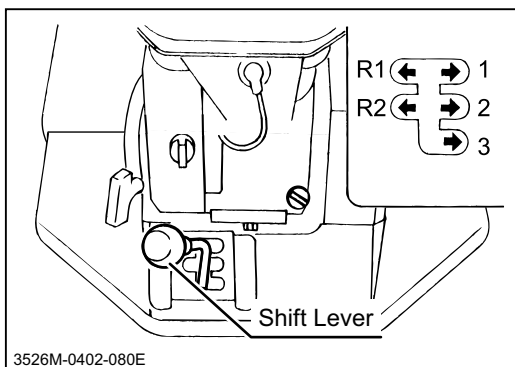

1. Stop machine.
2. Move shift lever firmly into a desired position.

NOTE

- Refer to "Product Specifications" (Page 10) for speed in each gear.
- When it is difficult to shift gears, move drive clutch lever toward [Run] position slightly and try again. It may help shifting smoothly.

Parking

⚠ WARNING!

- Always park on a firm, level ground. Never park on a potentially dangerous place.
- Avoid parking on a slope. Never park on a slope with an incline of 15 degrees or steeper. If it is absolutely necessary to park machine on a slope less than 15 degrees, make certain to apply parking brake firmly and block tracks with chocks.

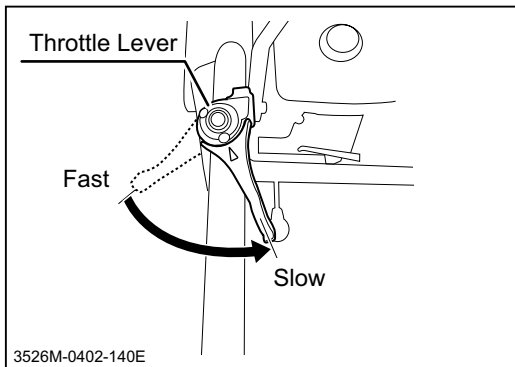

1. Stop machine.
2. Move throttle lever toward [Slow] position to decrease engine speed.

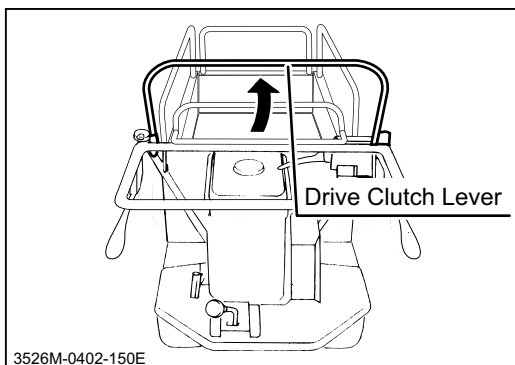

3. Lift the drive clutch lever to [Stop] position.

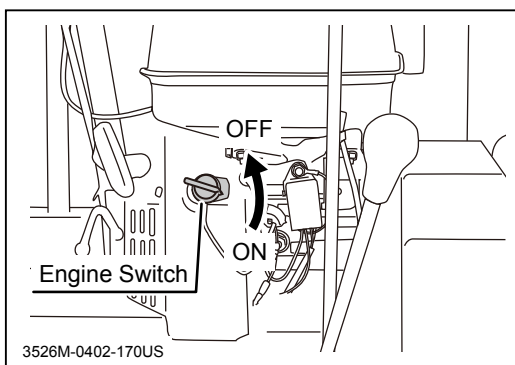

4. Turn the engine switch [OFF].

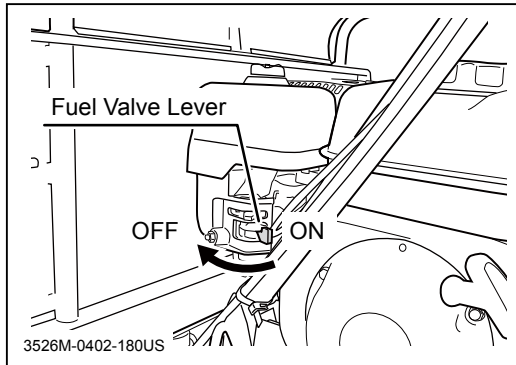

5. Turn the fuel valve lever [OFF].

NOTE

- Carbon deposit tends to accumulate on spark plug when running engine at low engine speed. When engine has been run at low engine speed for an extended period, run engine at high engine speed for a while before stopping engine to burn off carbone deposite.

Working

Dumping

⚠ WARNING!

- Always make certain of the safety of your surroundings when lifting or dumping.
- Do not lift or dump on a slope. Machine may tip over.

⚠ CAUTION!

- On hydraulic dump model, always run engine when lifting or dumping.
- When lowering loading deck with a load on it from a lifted or dump position, lower loading deck gently.

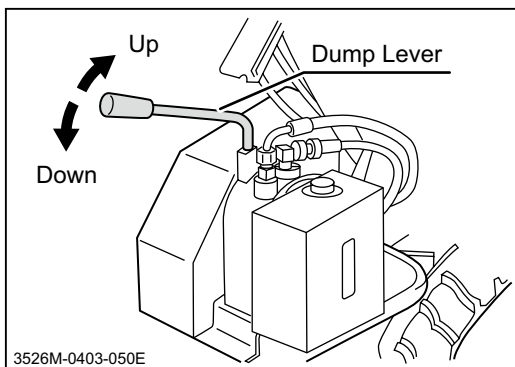

1. Start engine and raise engine speed.
2. Move dump lever to [UP] position to raise loading deck. When loading deck reaches the upper limit, hissing noise is heard. Release dump lever.
3. Move dump lever to [DOWN] position to lower loading deck. When loading deck reaches the lower limit, hissing noise is heard. Release dump lever.

Using Safety Prop

⚠️ WARNING!

- When it is necessary to inspect or work under loading deck, always hold loading deck in the raised position with safety prop. Failure to do so may result in injury or death.
- Make certain that safety prop securely hold the loading deck. Incomplete holding of the safety prop may result in injury or death.

⚠️ CAUTION!

- Make certain to undo safety prop before lowering loading deck.

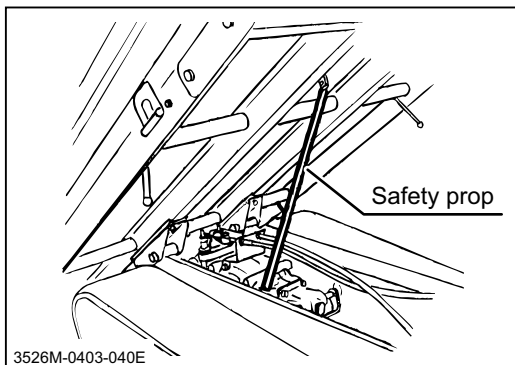

1. Raise loding deck
2. Hold loading deck with safety prop.

Maintenance Schedule

⚠ WARNING!

- Follow the scheduled maintenance as described below. Failure to do so may result in mechanical or property damage, injury or death.

- Perform a pre-startup inspection (PSI) before each use, a monthly inspection once a month, and a yearly inspection once a year.
- Some maintenance procedures described below may require special knowledge or tools and instruments. Contact your Canycom representative to perform such procedures.

Item	Description	Schedule			Note	
		PSI	Mon	Year		
Engine	Lubrication System	Oil shall be clean and at correct level.	√	√	√	Inspecting/ Changing:Page 32
		No noticeable oil leaks shall be found in head cover, oil pan, or pipes.	√	√	√	
	Air Cleaner	Air cleaner case shall not be deformed or cracked. Case lid and connecting air hose shall be firmly in place.		√	√	
		Cleaner element shall be in good shape without damage or excessive dust.	√	√	√	Cleaning/Replacing: Page 33
	Spark Plug	Electrode shall not be worn, and there shall not be excessive carbon deposit.			√	Cleaning/Replacing: Page 33
	Fuel System	There shall not be any leaks in fuel tank, hoses, or pipes.		√	√	
		Fuel hoses shall be free of damage or deterioration.		√	√	
		Fuel filter shall not be excessively dirty or clogged.		√	√	Cleaning: Page 34
		There shall not be sediment or water in the fuel tank.		√	√	
	Starting	Engine shall start easily without making any irregular noise.	√	√	√	
	Running	Engine speed shall be set properly at idle and at full throttle without load. Engine shall stay running smoothly.			√	Contact your Canycom representative for inspection.
		When accelerating engine, throttle lever shall move smoothly, and engine shall accelerate smoothly without stopping or knocking.	√	√	√	

Item	Description	Schedule			Note	
		PSI	Mon	Year		
Engine	Exhaust	Warm up engine thoroughly, and observe exhaust sound and gas from idle to fast speed; exhaust sound shall be normal and no smoke shall be observed.	√	√	√	
		There shall be no leak in exhaust system or muffler.		√	√	
	Fasteners	Bolts and nuts fastening cylinder head, intake and exhaust manifolds shall be tightly fastened. * this may be skipped if there is no gas leak found in these areas.			√	
	Valve Clearance	Valve clearance shall be correct. * this may be skipped if there is no noise due to incorrect valve clearance, and engine runs normally.			√	Contact your Canycom representative for inspection.
	Compression	Compression shall be normal * this may be skipped if running and exhaust condition is normal at idle and under acceleration.			√	Contact your Canycom representative for inspection.
	Engine Mount	Engine base shall be free of cracks or deformation.		√	√	
Mounting bolts and nuts shall not be loose or missing.		√	√	√		
Drive Train	Tracks	There shall not be marked cut, deterioration, or wear.	√	√	√	
		Track shall be properly tensioned; shall not be too loose or too tight.	√	√	√	Adjusting: Page 35
		Tension bolt shall be free of deformation or corrosion.	√	√	√	
	Transmission	Transmission shall not jump out of the gear. Irregular noise or overheating shall not be observed.	√	√	√	
		Oil shall be clean and filled to the proper level.		√	√	Replacing: Page 36
		There shall not be oil leaks in or around transmission.		√	√	

Item	Description	Schedule			Note	
		PSI	Mon	Year		
Drive Train	Drive Belts	Belt tension shall be properly adjusted.		√	√	Inspecting/Adjusting: Page 37
		Belt shall be free of damage, excessive wear, or dirt; shall be free of oil or grease.		√	√	
	Clutch	Clutch shall not make noise and shall disengage completely when operated at idle.		√	√	
		Clutch shall not slip and shall engage smoothly.		√	√	
	Brake	Brake shall work properly.	√	√	√	Adjusting: Page 38
		Parking brake shall be able to hold the machine on the 20-degree slope.		√	√	
	Side Clutch	Side clutch shall work positively without making irregular noise.	√	√	√	
		Lever play and stroke shall be properly adjusted.	√	√	√	Inspecting/Adjusting: Page 39
		Wire shall be free of damage, excessive play at joints, or rust on pins.		√	√	
	Linkage	Rods, links, and wires in linkage shall be free of deformation or damage.		√	√	
		Connections shall be free of looseness, excessive play, or missing cotter pins.		√	√	
	Undercarriage	Wheels Sprockets Idlers	Shall be free of cracks, defromation, or excessive wear.	√	√	√
There shall not be excessive play in axle. Irregular noise or overheating shall not be observed when traveling.			√	√	√	
Mounting bolt or nut shall not be loose or missing.			√	√	√	
There shall be no oil leak in or around axle.				√	√	
Linkage		Rods, links, and wires in linkage shall be free of deformation or damage.		√	√	
		Connections shall be free of looseness, excessive play, or missing cotter pins.		√	√	

Item	Description	Schedule			Note
		PSI	Mon	Year	
Body, Chassis, Loading Deck, Safety Devices	Chassis Frame	Shall be free of cracks, deformation, or corrosion.	√	√	
		Fastening bolts or nuts shall not be loose or missing.	√	√	
	Body Panels	Shall be free of cracks or deformation.	√	√	
		Fastening bolts or nuts shall not be loose or missing.	√	√	
	Loading Deck	Loading deck shall be raised and lowered smoothly.	√	√	
		Panels shall slide smoothly and can be locked in place securely.	√	√	
		Shall be free of cracks, deformation, or corrosion.	√	√	
		Fastening bolts or nuts shall not be loose or missing.	√	√	
	Lock	Lock shall be free of bent or deformation and work positively.	√	√	
	Safety Prop	Safety prop shall be free of any deformation.	√	√	
Labels	Warning labels and instruction plates shall be clean, legible, and free of damage.	√	√		
Hydraulic	Hydraulic Package	Oil shall be clean and at correct level.	√	√	Inspecting/Changing: Page 41
		No noticeable oil leaks shall be found in or near hydraulic package.	√	√	
		Fastening bolts or nuts shall not be loose or missing.	√	√	
		Breather is not clogged.		√	
		No noticeable oil leaks shall be found in the joints and seals of hoses and pipes.	√	√	
		No abnormal noise, vibration or overheating shall be observed when hydraulic package is working.	√	√	

Item	Description	Schedule			Note	
		PSI	Mon	Year		
Hydraulic	Hydraulic Package			√	Inspecting/Changing: Page 41	
	Plumbing	There shall be no crack, deforeamation, deterioration or twisting found in the plumbing.		√	√	
		No oil leak shall be found in the joints.		√	√	
		Plumbing shall be mounted tightly and fastening bolts or nuts shall not be loose or missing.		√	√	
	Hydraulic Cylinder	Moves smoothly.		√	√	
		There shall be no oil leak when cylinder is extended.		√	√	
		Put a load on cylinder. The amount of sag shall be within the value specified by the manufacturer.			√	
		There shall be no dent, crack, bending or scratche on the cylinder tube or cylinder rod.		√	√	
		There shall be no marked wear or damage on cylinder mounting pins.		√	√	

List of Fluids and Lubricants

Item	Schedule	Grade	Cap.	Ref.
Fuel	As needed.	Automotive unleaded gasoline.	3.1L (0.82 US gal)	page 12
Engine Oil	Fill Inspect daily. Fill as needed. Replace Initially - After 25 hours of use. Every 50 hours afterwards.	Automotive gasoline engine oil API rating: SE or better. SAE rating: 10W-30	0.58L (0.61 US qt)	page 32
Transmission Oil	Replace Initially - After 50 hours of use. Every 500 hours afterwards.	Gear Oil API rating: GL-4 or 5 SAE rating: #80	1.5L (1.59 US qt)	page 36
Hydraulic Fluid	Inspect every 100 hours. Fill as needed.	Gear Oil API rating: GL-4 or 5 SAE rating: #90 (In cold area, use 10W-30 engine oil)	1.6L (1.69 US qt)	page 41
Lubrication for drive clutch lever supporting point and tension arm supporting point.	Every 6 months. * No need to lubricate for 6 months after purchase.	Gear Oil API rating: GL-4 or 5 SAE rating: #80	-	page 40

List of Consumables and Spares

⚠ CAUTION!
<ul style="list-style-type: none"> • When replacing consumable or spare, always use CANYCOM genuine part. • Using non-genuine parts may void warranty.

Item	Schedule	Qty.	Reference
Air Cleaner Element	Inspect every 50 hours(every week). Replace if there is any failure	1	
Fuel Cock (Fuel Filter)	Inspect every 200 hours (every month)	1	
V- Belt	Repalce if there is any failure	2 kinds 1 each	Please contact your CANYCOM representative for replacement
Brake Lining	Repalce if there is any failure	1 Set (Replace whole set)	Please contact your CANYCOM representative for replacement
Crawler	Repalce if there is any failure	2	Please contact your CANYCOM representative for replacement
Other parts need to be replaced than the above	Please contact your CANYCOM representative for inspection.	-	-

Engine

⚠ WARNING!

- Always stop engine before servicing.
- Allow engine to cool off before servicing. Engine is very hot after operation and may pose a burn hazard.
- Keep fire and spark away when handling fuel.

Engine Oil

⚠ CAUTION!

- Dispose of drained oil properly.
- Make certain to fill engine with correct grade of oil to the specified level. Insufficient amount or wrong grade of oil reduces performance and may cause permanent damage to engine.
- Be cautious with high temperature oil may cause burn injury.

NOTE

- To obtain correct reading, check oil level before starting, or wait about 10 minutes after stopping engine to allow oil to drain back to oil pan. Circulating oil stays in various parts of engine right after stopping.
- Always check oil level on a level ground.
- Recommended Oil and Quantity: see "List of Fluids and Lubricants" (page 30)
- Dispose drained oil properly.

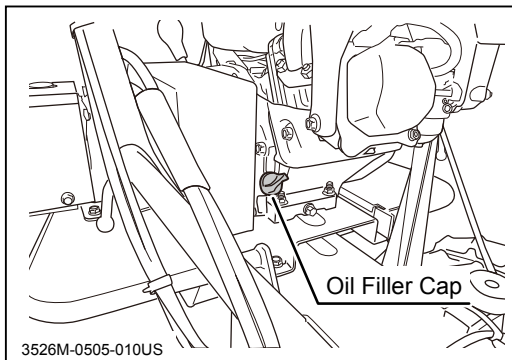

Inspecting / Refilling

1. Park machine on a level surface.
2. Remove oil filler cap.
3. Follow the instructions in "**Operator's Manual for the Engine**" to check oil.
4. If oil level is low, fill oil according to the engine manual.
5. Install oil filler cap.

NOTE

- Oil to use : See page 30

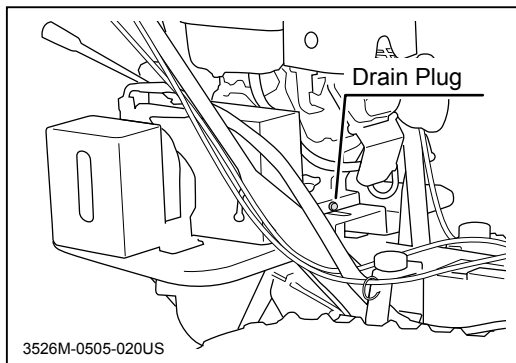

Changing

1. Have an appropriate oil drain pan.
2. Remove oil drain plug and drain oil inside the crank case.
3. Install oil drain plug.
4. Open oil filler plug and refill specified oil.

Air Cleaner Element

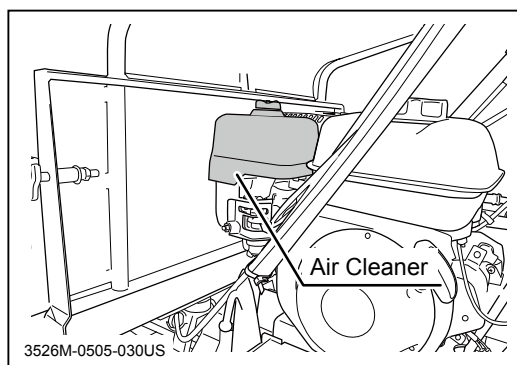

1. Follow the instructions in "**Operator's Manual for the Engine**" to clean or replace air cleaner element.

Spark Plug

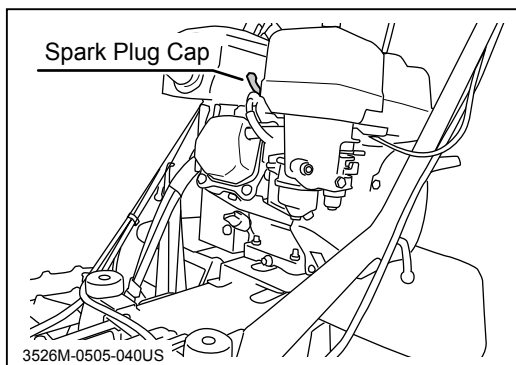

Inspecting

1. Remove spark plug cap.
2. Remove the spark plug using plug wrench.

NOTE

- Always hold and remove the spark plug cap never pull the cord to remove the cap.

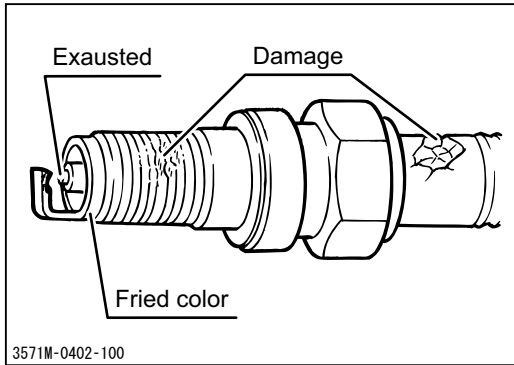

3. Apply inspection listed below and clean or replace if there is failure.
 - Damage on insulation
 - Condition of electrode
 - Accumulated carbon
 - Damage of gasket
 - Condition of insulator for spark part

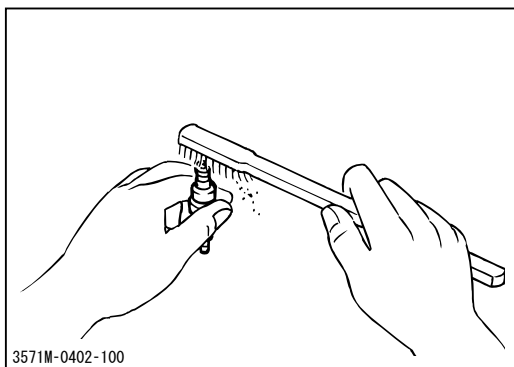

Cleaning

1. Clean the spark plug with wire brush or plug cleaner.

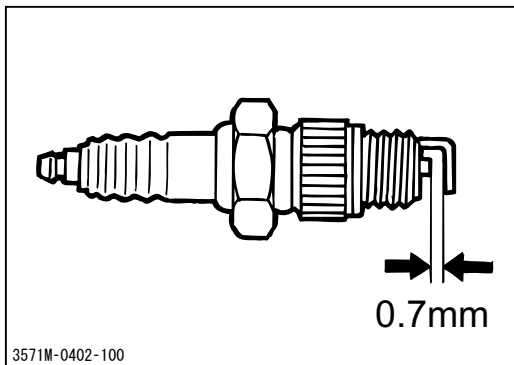

2. Adjust the gap between the electrode grinding with sand paper.
3. Install spark plug.

NOTE

- Standard value: 0.7mm (0.0276in)

Fuel Cock (Fuel Filter)

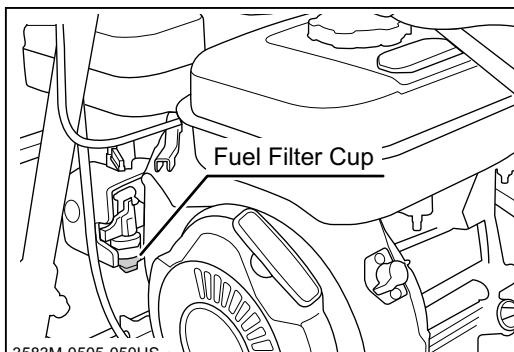

Cleaning

1. Follow the instructions in "**Operator's Manual for the Engine**" to clean fuel filter.
2. Start engine and visually inspect fuel filter cup so that there is no leak.

Drive Train

⚠️ WARNING!

- Stop the engine when servicing the drive train.
- Allow the machine to cool off before servicing. The engine is very hot after operation and may pose a burn hazard.

⚠️ CAUTION!

- Dispose of drained oil and fluids properly.

Track

⚠️ WARNING!

- Jack up the machine securely when inspecting and adjusting the track. Jack it up on a level ground.
- Always unload the machine before jacking up.
- Make certain to adjust track tension properly. Improperly tensioned tracks may wear or come off, resulting in property damage, serious injury or death.

NOTE

- Track stretches during its use-life. Inspect and adjust regularly.

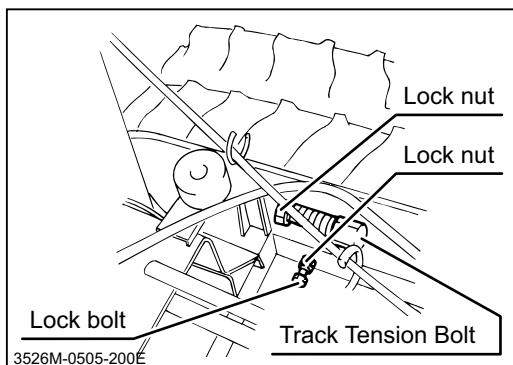

1. Jack up machine so that track is parallel to the ground.
2. Lift up the loading deck. (see page 22)
3. Loosen lock nut and lock bolt
4. Loosen lock nut of the track tension bolt.

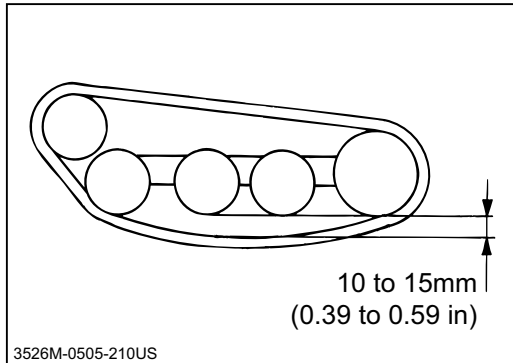

5. Adjust track tension bolt so that the clearance between track and center roller (clearance A) at the furthest is between 10 and 15mm (0.39 and 0.59 in).
6. Surely tighten the lock bolt, lock nut and lock nut of the track tension bolt.
7. Lift down the loading deck (see page 22)

Transmission Oil

⚠ CAUTION!

- Dispose of drained oil and fluids properly.

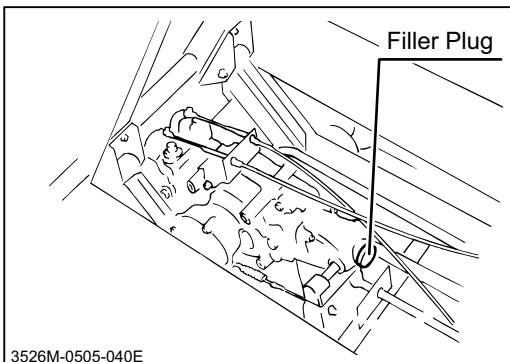

Inspecting / Refilling

1. Remove oil filler plug.
2. Visual check the amount and the clarity of the oil. Replace or refill the oil if necessary.
3. Install oil filler plug.

NOTE

- Oil to use : See page 30

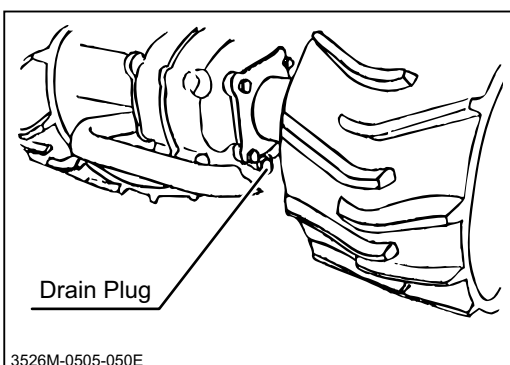

Replacing

1. Have an appropriate oil drain pan.
2. Remove oil drain plug and drain oil inside the crank case.
3. Install oil drain plug.
4. Open oil filler plug and refill specified oil.

V - Belt

⚠ CAUTION!

- Adjust belt tension properly. Inproperly tensioned belt may reduce performance and its service life.

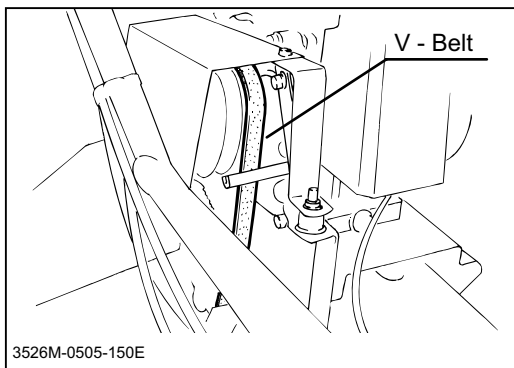

Inspecting - Engine V - Belt

1. Visually check if drive belt damaged or not. Replace the belt if necessary.

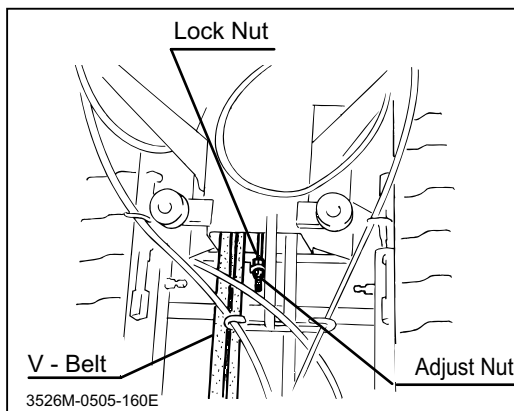

Middle V - Belt

1. Visually check if V - belt damaged or not. Replace the belt if necessary.
2. Adjust the deflection of the V - belt with loosen the lock nut and tighten the adjust nut of the tension volt. If the belt deflect about 10mm by pressing your finger, it has adjusted properly.
3. Surely tighten the lock nut arter adjustment.

NOTE

- Please contact your CANYCOM representative for replacing the belt.

Belt Stopper

⚠ CAUTION!

- Inappropriate adjustment cause incomplete disengagement of the clutch. Adjust the belt stopper when you remove the stopper.
- Always stop the engine for adjustment.

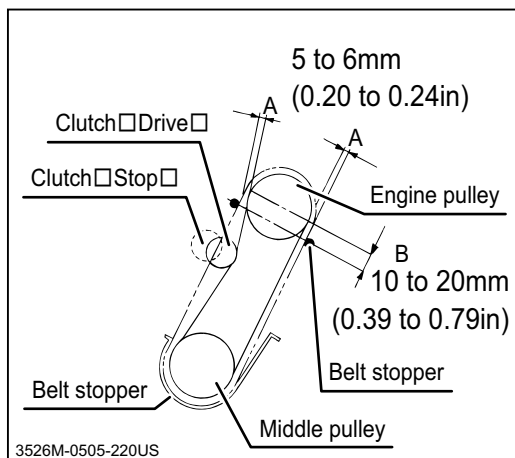

1. Remove safety cover.
2. Move clutch lever to [Drive] position. Adjust clearance between 5 to 6 mm (0.20 to 0.24in) for clearance A and 10 to 20 mm (0.39 to 0.79in) for clearance B.
3. Adjust the clearance about 5mm (0.20in) for belt stopper and belt.

Brake

⚠ CAUTION!

- Immediately adjust the brake if you feel the brake works unusually by method below. Drive safely at any time.

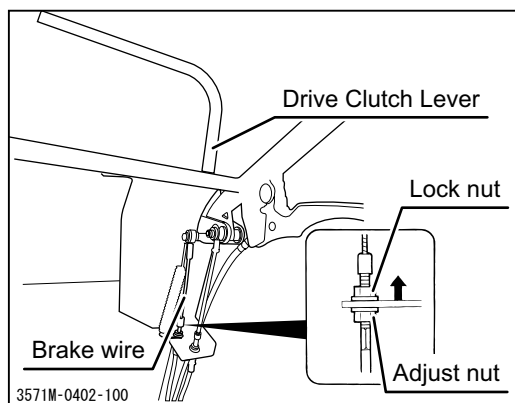

1. Move clutch lever to drive position and make the brake wire free from tension.
2. Loosen the lock nut of the brake wire.
3. Adjust the wire with rotating the adjust nut.
 - If you feel brake is weak then move the adjust nut toward arrow mark in the picture. Adjust the spring between transmission and brake wire extends about 5mm.
4. Surely tighten the lock nut after adjustment.

Drive Clutch

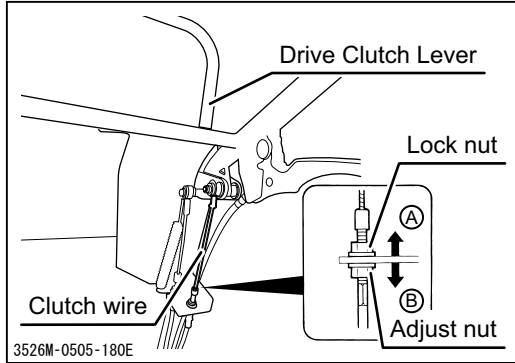

1. Move clutch lever to stop position and make the clutch wire free from tension.
2. Loosen the lock nut of the clutch wire.
3. Adjust the wire with rotating the adjust nut.
 - If declutches inappropriately, rotate adjust nut toward direction A.
 - If the V- belt slips, rotate adjust nut toward direction B.
4. Surely tighten the lock nut after adjustment.

Side Clutch

⚠ CAUTION!

- If the allowance increases or rotate nonsmoothly, adjust with the adjust nut of the clutch wire.

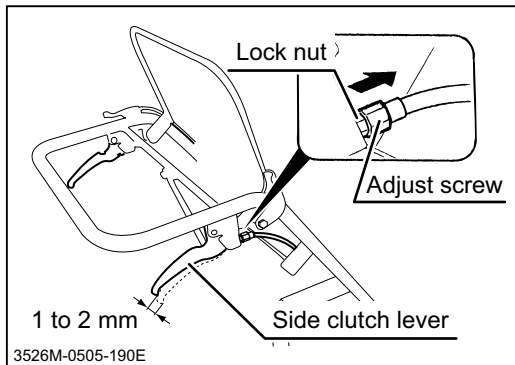

1. Loosen the lock nut of the side clutch wire.
2. Rotate the adjust nut toward arrow mark in the picture to adjust the allowance.
3. Surely tighten the lock nut after adjustment.

Lubrication

⚠ CAUTION!

- Follow the maintenance schedule to lubricate machine. Lack of lubrication may result in rust, excessive wear or seizure.

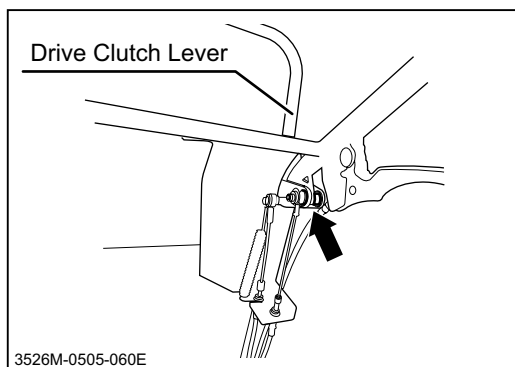

1. Supporting Point - Drive Clutch Lever (Right)

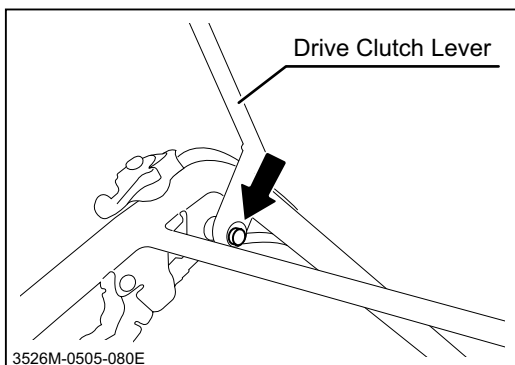

2. Supporting Point - Drive Clutch Lever (Left)

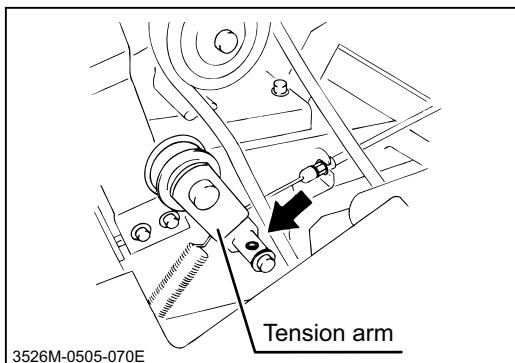

3. Supporting Point - Drive Clutch Lever Tension Arm

Hydraulic System (Hydraulic Dump Model)

⚠ WARNING!

- Stop engine when servicing drive train.
- Allow machine to cool off before servicing. Engine is very hot after operation and may pose a burn hazard.

Hydraulic Package

⚠ CAUTION!

- Make certain to fill hydraulic package with specified fluid to the specified level. Insufficient amount or wrong grade of fluid reduces performance and may cause permanent damage to engine.
- Dispose of drained oil and fluids properly.

NOTE

- To obtain correct reading, check hydraulic fluid level with loading deck in the lowered (not lifted or dumped) position.
- Always check hydraulic fluid level on a level ground.
- Recommended Oil and Quantity: see "List of Fluids and Lubricants" (page 30)

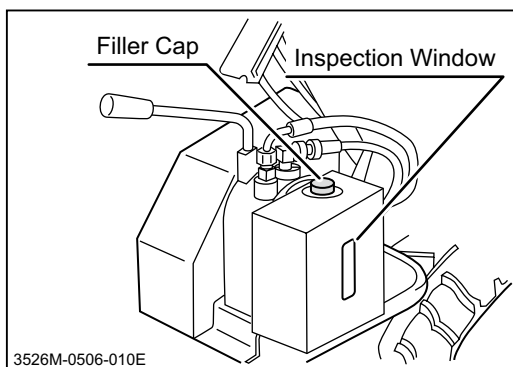

Inspecting

1. Park machine on a level ground.
2. Visually inspect the hydraulic fluid level. Make certain the fluid level is above 600 line.
3. If fluid level is low, fill fluid.

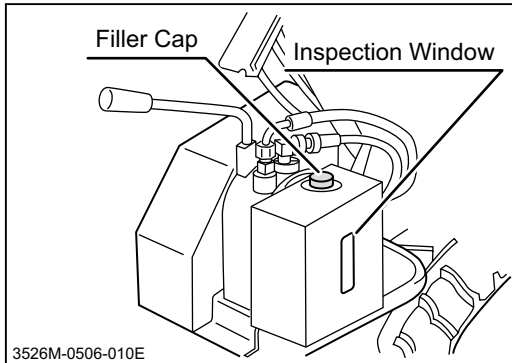

Filling

1. Remove filler cap. Fill fluid.
2. Put filler cap back in place firmly.
3. Run engine for a while to circulate hydraulic fluid.

Hydraulics Belt

⚠ CAUTION!

- Adjust belt tension properly. Improperly tensioned belt may reduce performance and its service life.

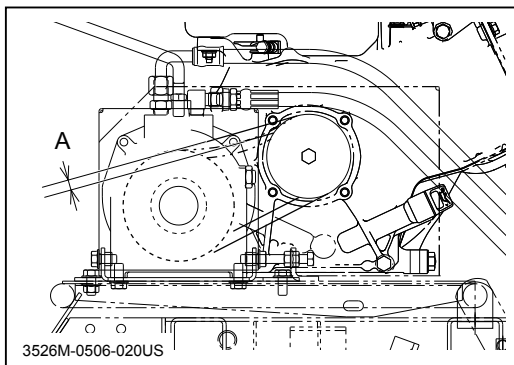

Inspecting

1. Remove belt cover.
2. Inspect drive belt tension. Push on the middle of hydraulics belt with a finger to see if its sag A is about 10mm (0.39in). If not, adjust.
3. Visually inspect drive belt for damages. If damaged, contact your dealer to replace it.
4. Install belt cover.

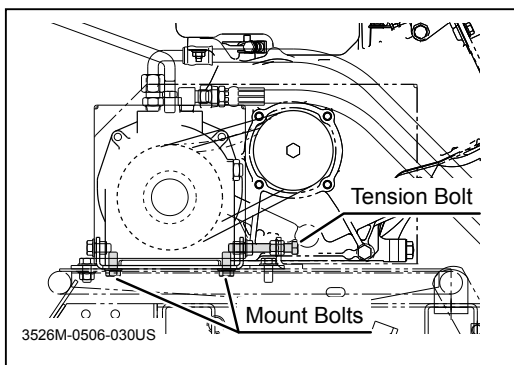

Adjusting

1. Remove belt cover.
2. Loosen four mount bolts.
3. Adjust belt tension with tension bolt so that it sags about 10mm (0.39in) when the middle of the belt is pushed by a finger.
4. Tighten four mount bolts.
5. Install belt cover.

After Use Care

⚠ CAUTION!

- Do not wash the engine, control panel, electrical parts, or tank caps with air breather with running water; water may enter inside and cause rust or damage.
- Clean the machine after use; leaving dirt or foreign objects may cause damage.
- Do not attempt to move the machine when it becomes inoperable due to freezing.

After Normal Use

1. Clean the machine; wash off dirt, mud, and other foreign matter after use.
2. If the machine is to be left outside, cover the machine with protective, water-proof covering after the machine is cooled off.

After Cold Weather Use

1. Clean the machine; wash off dirt, mud, and other foreign matter after use.
2. Park the machine on a paved or firm, dry surface.
3. If the machine is to be left outside, cover the machine with protective, water-proof covering after it is cooled off.

Storage

⚠ WARNING!

- Fire hazard; do not store the machine where there is a possibility of ignition.

⚠ CAUTION!

- Do not wash the engine or control panel with running water; water may enter inside and cause rust or damage.
- Clean the machine before storage; leaving dirt or foreign objects may cause rust or damage.
- Do not store the machine in a humid, dusty, or hot place.

1. Follow the instructions in "**Parking**" (page 21) to park the machine.
2. Clean dirt off of the machine.
3. Follow instructions in "**Operator's Manual for the Engine**" to prepare engine for storage.
4. Cover the machine with protective, water-proof covering after the machine is cooled off.

NOTE

- Refer to "**Operator's Manual for the Engine**", for detailed instructions on preparing the engine for storage.

Troubleshooting

- If any malfunction or abnormal condition is found, immediately stop using the machine and take an appropriate measure according to the Troubleshooting chart below. If the malfunction or abnormal condition is not listed in the chart, or the suggested measure does not solve the problem, consult with your CANYCOM representative.
- Some corrective measures listed below require special knowledge and/or equipment. Please contact your CANYCOM representative in such a case.

Area	Malfunction	Possible Cause	Corrective Measure	Ref.
Engine	Engine does not start, or is difficult to start.	Out of fuel.	→Fill fuel.	Page 12
		Engine is flooded (too much fuel fed into the engine).	→Wait and restart.	
		Fuel cock is closed	→Open fuel cock.	Page 14
		Poor ignition due to a problem with spark plug.	→Clean or replace spark plug.	Page 33
		Other (other than the above).	→Follow the instructions in " Starting " to restart. If problem persists, please contact your CANYCOM representative.	Page 13
	Engine stalls.	Out of fuel.	→Fill fuel.	Page 12
		Engine is cold.	→Warm up engine.	Page 16
		Choke lever is in [Close] position.	→Move choke lever to [Open] position.	Page 16
		Other (other than the above).	→Please contact your CANYCOM representative.	
	Engine stops abruptly.	Out of fuel.	→Fill fuel.	Page 12
		Other (other than the above).	→Please contact your CANYCOM representative.	

Area	Malfunction	Possible Cause	Corrective Measure	Ref.
Engine	Irregular Idling	Air cleaner element is clogged	→Clean or replace air cleaner element.	Page 33
		Other (other than the above).	→Please contact your CANYCOM representative.	
	Poor power or acceleration	Bad fuel	→Change fuel.	
		Insufficient intake air (clogged air cleaner).	→Clean or replace air cleaner element.	Page 33
		Loose drive belt.	→Adjust drive belt.	Page 37
		Excessive load	→Reduce load.	
		Other (other than the above).	→Please contact your CANYCOM representative.	
	Irregular noise or vibration from or around the engine		→Please contact your CANYCOM representative.	
	Excessive oil consumption		→Please contact your CANYCOM representative.	
	Engine overheats	Insufficient amount of engine oil.	→Fill oil.	Page 32
		Other (other than the above).	→Please contact your CANYCOM representative.	
	Excessive Fuel consumption	Insufficient intake air (clogged air cleaner).	→Clean or replace air cleaner element.	Page 33
		Other (other than the above).	→Please contact your CANYCOM representative.	
	Black smoke comes out of exhaust	Choke lever is in [Close] position.	→Move choke lever to [Open] position.	Page 16
		Air cleaner is clogged.	→Clean or replace air cleaner element.	Page 33
Other (other than the above).		→Please contact your CANYCOM representative.		

Area	Malfunction	Possible Cause	Corrective Measure	Ref.
Engine	White or blue smoke comes out of exhaust	Bad fuel.	→Change fuel.	
		Engine oil level is too high.	→Adjust the oil level.	Page 32
		Wrong engine oil.	→Change oil.	Page 32
		Other (other than the above).	→Please contact your CANYCOM representative.	
	Accelerator lever is catching		→Please contact your CANYCOM representative.	
Drive Train	Machine does not move when clutch lever is in the [Run] position.	Transmission is not positively in the gear.	→Shift firmly.	
		Loose drive belt.	→Adjust drive belt	Page 37
		Other (other than the above).	→Follow instructions in "Driving" to drive. If problem persists, please contact your CANYCOM representative.	Page 16
	Clutch does not disengage positively.	Improperly adjusted drive belt.	→Adjust drive belt	Page 37
		Other (other than the above).	→Please contact your CANYCOM representative.	
	Drive belt slips.	Loose drive belt.	→Adjust drive belt	Page 37
		Other (other than the above).	→Please contact your CANYCOM representative.	
	Transmission jumps out of gear.	Transmission is not positively in the gear.	→Shift firmly.	
		Excessive load	→Reduce load.	
		Other (other than the above).	→Please contact your CANYCOM representative.	
	Excessive play with the side clutch.	Improperly adjusted side clutch.	→Adjust side clutch	Page 39
	Machine does not turn smoothly.	Improperly adjusted side clutch.	→Adjust side clutch	Page 39
		Other (other than the above).	→Please contact your CANYCOM representative.	

Area	Malfunction	Possible Cause	Corrective Measure	Ref.
Drive Train	Irregular noise or abnormal heat from roller, sprocket, or idler.		→Please contact your CANYCOM representative.	
Brake	Brake does not work well.	Improperly adjusted brake.	→Adjust brake.	Page 38
		Brake is wet with water.	→Apply brake a few times to dry.	
		Excessive load	→Reduce load.	
		Other (other than the above).	→Please contact your CANYCOM representative.	
Track	Track does not move smoothly.	Improperly adjusted track.	→Adjust track.	Page 35
		Other (other than the above).	→Please contact your CANYCOM representative.	
Hydraulic System	Hydraulic system does not work or does not work properly.	Hydraulic fluid is insufficient or deteriorated	→Add or change hydraulic fluid.	
		Loose V-belt.	→Adjust V-belt	
		Other (other than the above).	→Please contact your CANYCOM representative.	

Hauling

Loading and Unloading

⚠️ WARNING!

- Park transporter (truck) on a level ground. Always use chocks to secure wheels.
- Do not allow bystandars to come close to machine or transporter when loading or unloading machine.
- Use only the loading ramps with sufficient strength (to withstand the combined weight of machine and operator), width (more than 2 times the width of track), and length (more than 4 times the height of loading deck of transporter), and have anti-slip ramp surfaces.
- Secure hooks of loading ramps firmly and flush with loading deck of transporter.
- Move slowly forward when loading onto, and move slowly backward when unloading off of transporter. Pay special care when going over the joint between loading deck and ramps; machine may tip.
- Do not turn on loading ramps. Machine may fall.
- Tie down machine securely. Make sure machine does not move around on loading deck.

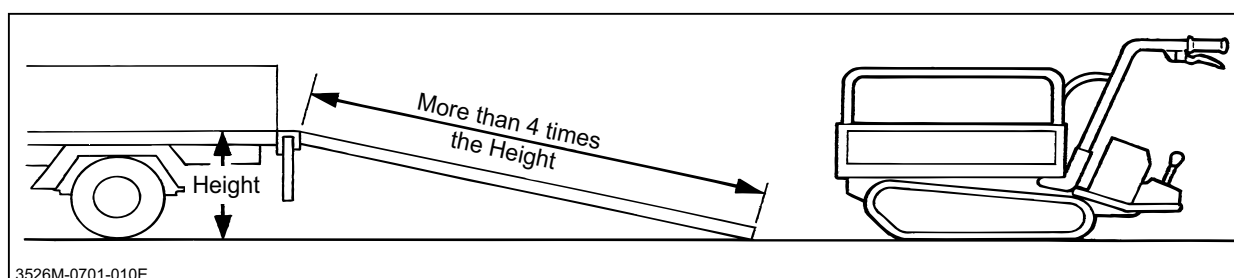

1. Park transporter on level ground. Secure wheels with chocks.
2. Place loading ramps. Secure hooks of ramps firmly and flush with loading deck of transporter.
3. Drive machine slowly forward onto loading deck.
4. Park machine according to the instructions in "**Parking**" (page 21). Secure machine firmly to loading deck of transporter with tie-down belts, rope, or wire.

CHIKUSUI CANYCOM, INC.

<http://www.canycom.jp/eng/>

CHIKUSUI CANYCOM, INC.
90-1 Fukumasu, Yoshii-machi,
Ukiha-shi, Fukuoka, Japan 839-1396

Sales Headquarters TEL +81-(0)943-75-2195
FAX +81-(0)943-75-4396

Authorized Dealer