

Off-road Rubber Track Dumper

S100B





Operator's Manual



Warning Terms Used in this Manual

Thank you for purchasing this product.

In this manual, the following four warning terms are used to signal the four levels of hazard (or seriousness of possible accidents). Read and understand what they mean and always follow the instructions in this manual.

Warning Term	Definition
	Indicates an imminently hazardous situation which will result in death or serious injury if the user does not follow the procedures or the instructions.
	Indicates a potentially hazardous situation which could result in death or serious injury if the user does not follow the procedures or the instructions.
	Indicates a potentially hazardous situation which could result in minor to moderate injury or damage to the product if the user does not follow the procedures or the instructions.
	Indicates important information which needs particular attention.

Notice to Users and Maintenance Personnel

This manual provides information needed for safe and effective use of this product to those who operate or maintain this product. Make sure to read and understand the manual thoroughly before operating this product. Also make sure to read the separate operator's manual for the engine.

WARNING

- This product can be very dangerous if the safety precautions in this manual and on the labels attached to this product are not followed. Read and understand this manual and the safety labels on the product thoroughly before using this product. Always follow the instructions and safety precautions, or serious injury or death could result.
- This product should only be used for its intended purpose: hauling and dumping. Any other use could be dangerous.
- This product may not be operated on public road or what is considered to be public road. It is the sole responsibility of the operator to consult the local regulations.
- Do not modify this product, or do not operate this product with the safety covers removed or open. A serious accident could result.

CAUTION

- Store this manual in a safe, accessible place for easy reference.

Notice to Owner or Renter

CAUTION

- Be sure that everyone who uses this product, including those who rent or lease this product, receives a copy of this Operator's Manual and understands the importance of reading and following the information in this manual.
-

Warranty and After-Sales Service

Warranty

CHIKUSUI CANYCOM, INC. guarantees this product, based on the terms of warranty.

After-Sales Service

Consult your local CANYCOM dealer or our company's sales department regarding service orders or any questions or problems that may arise when using this product. Please make sure to have the product name, serial number, and the make and type of the engine handy at the time of contact. The model and serial number can be found on the model label as shown below, and the make and type of the engine can be found in Chapter3 "Specifications" of this manual (Page14).

Location of Model Label

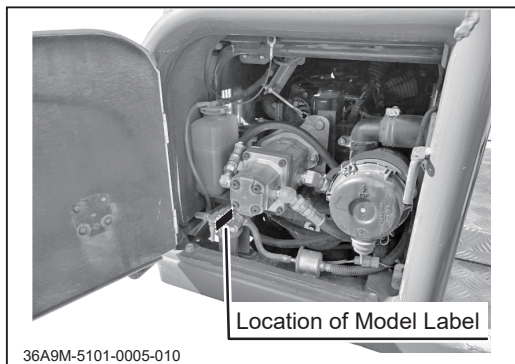

Model Label

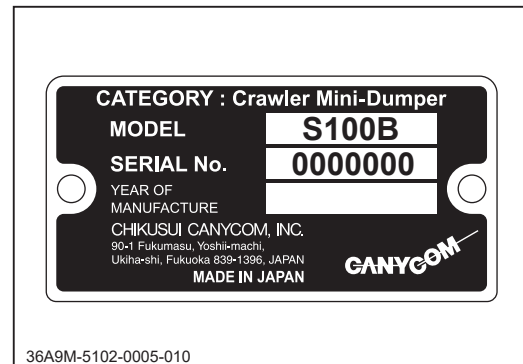

Availability of Spare Parts

The replacement or repair parts for this product shall remain available for nine years after the production of this type of product is discontinued.

Contents

1. Safety	1
Safety Labels	1
Safety Precautions	4
Training	4
Preparation	5
Operation	5
Servicing	10
2. Controls and Components	11
Name and Function of Controls	11
3. Specifications	14
Product Specifications	14
Contents of Tool Bag	15
4. Operation	16
Preparation	16
Pre-start up Inspection	16
Checking and Filling Fuel	16
Adjusting Seat	17
Driving	18
Starting	18
Driving	23
Stopping and Parking	26

Working	28
Dumping	28
Swiveling Bucket	29
Using Safety Prop	30

5. Maintenance **32**

Maintenance Schedule	32
List of Fluids and Lubricants	38
List of Fluids and Lubricants	38
Greasing	39
Consumables and Spares	40
Engine	41
Engine Oil	41
Oil Filter Cartridge	43
Air Cleaner	44
Coolant	46
Fan Belt	47
Fuel System	48
Bleeding Air in the Fuel System	48
Draining Water Separator	49
Draining Water From Fuel Tank	49
Fuel Filter	50
Hydraulic System	51
Hydraulic Oil	51
Suction Filter	53
Oil Line Filter Cartridge	54
Hydraulics Belt	54

Drive Train	55
Tracks	55
Drive Lever	57
Transmission Oil	59
Drive Belt	60
Parking Brake	61
Electrical System	62
Battery	62
Fuses	64
Relays	66
After Use Care	67
After Normal Use	67
After Cold Weather Use	67
Washing	68
Storage	69

6. Troubleshooting 71

Troubleshooting 71

7. Transporting 78

Hauling 78

Loading and Unloading 78

Hoisting 80

Folding ROPS (for transportation and storage) 81

Appendix

- Operator's Manual for the Engine.

* Be sure to read and understand it together with this manual .

Safety Labels

The safety labels shown in the next pages are attached to the machine. See the illustration in the following pages for the location and the content of each label on the machine.

- **Locate all the warning labels attached to this machine. Read and follow the instructions and precautions in them. Failure to do so could result in serious injury or death to the operator or bystanders.**
- **Keep the labels clean and legible. Do not use solvents or gasoline to clean the labels.**
- **Replace these labels immediately if they have been removed, have fallen off or become illegible. Use the part number, on the label or shown in this manual, to order a replacement label from your CANYCOM representative.**

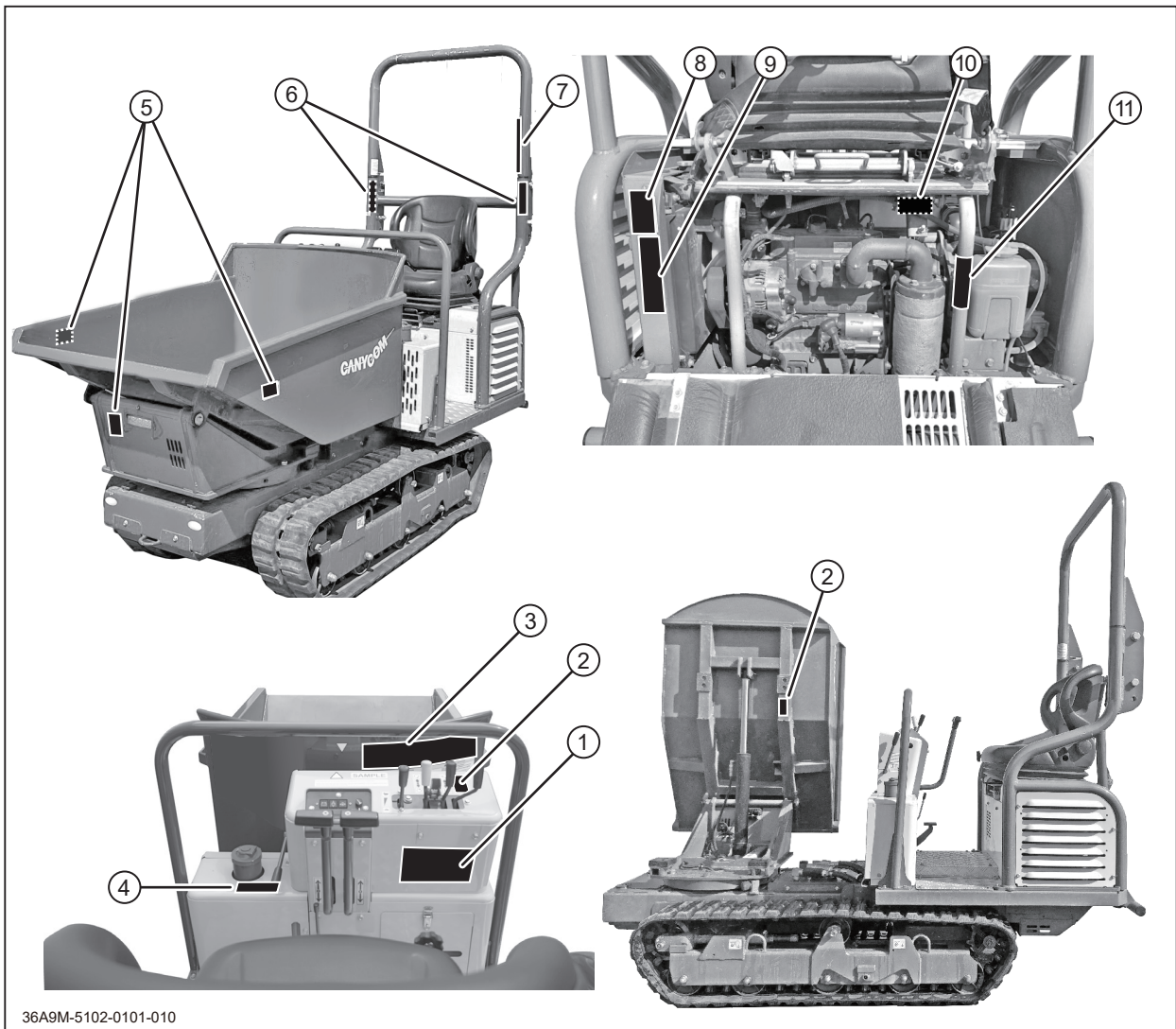

36A9M-5102-0101-010

① 36A4 5013 000

⚠ WARNING! AVERTISSEMENT! WARNUNG! AVVERTENZA!

Always stop the engine and apply the parking brake before leaving the machine.
When the steering lever is touched while the engine is running, the machine will move.

Arrêtez toujours le moteur et serrez le frein de parking avant de quitter la machine. Une action sur les leviers de translation alors que le moteur tourne engendre le déplacement de la machine.

Stellen Sie den Motor ab und betätigen Sie aus Sicherheitsgründen immer die Parkbremse bevor Sie die Maschine verlassen. Wenn Sie bei laufendem Motor die Fahrpedalhebel betätigen, beachten Sie bitte, dass die Maschine sich entsprechend in Bewegung setzt.

Spegnera sempre il motore ed azionare il freno di parcheggio prima di scendere dalla macchina. Toccare le leve dello sterzo quando il motore è in moto causa il movimento della macchina.

⚠ CAUTION / ATTENTION

Caution when Dumping
Always start engine before tipping.

précaution à prendre contre le basculement
assurez-vous pour basculer que le moteur est en route.

achtung beim kippen
lassen sie vor der betätigung des kippers immer zuerst den motor laufen.

36A4 5013 000

② 3677 5046 001











⚠ DANGER!



Crush hazard. To prevent death or serious injury, do NOT place any part of your body under the loading deck.

3677 5046 001

③ 36A4 5014 100

⚠ WARNING						 LWA 102dB
						
Accelerate or decelerate slowly. Sudden starts, stops, or turns can cause tip-over. Avoid running over obstacles.	Never operate on a slope steeper than 25 degrees. Observe load limits when operating on a slope below that angle.	Upsel hazard. To avoid serious injury or death, do NOT rotate and dump on an incline.	Electric shock hazard. Keep away from electric power lines and utility poles.	Moving fan blades can sever hand and fingers. Keep hands away to avoid injury.	Moving bolts can entangle hand and arm. Keep hands away to avoid injury.	
⚠ WARNING		⚠ DANGER		⚠ CAUTION		
				Warm up!		
Hazardous voltage. Use of unapproved test probes on conductive objects is strictly prohibited. See operation manual.	Read and FULLY understand the operator's manual before use or maintenance.	Power sources. Hydraulic and electric power sources are present. Lockout ALL energy sources before servicing.	Noise Hazard. Wear approved ear protection during operation.	In the cold weather, warm up the machine thoroughly. -Driving the machine without warming up can harm or damage it. -Make certain that no part of machine is frozen. If any part is frozen, thaw it before driving or operating. - Make sure that when connecting Booster Cables that positive (+) goes to positive (+) and negative (-) goes to negative (-) terminals on the batteries. Insecure leads may cause difficulty in starting engine, damage of electrical system possibly resulting in a fire or explosion. -Always connect the positive (+) cable first and disconnect last. - Misconnection of the terminal may result in damage of electrical system. - When connecting Booster Cables do not allow the positive (+) terminal of the Booster Cables to come into contact with negative (-) terminal or Booster Cable or any other metal parts.		

36A4 5014 100

⑥ 3677 5055 000

⚠ DANGER!



Crush Hazard
Keep hands away from ROPS joint. Shearing action of ROPS can cause serious injury or death.

3677 5055 000

④ 36A4 5017 000



⑤ 3677 5044 001

⚠ WARNING!



Impact hazard. Keep away from the machine in operation. The machine or its equipment may move suddenly.

3677 5044 001

⑦ 3677 5056 000

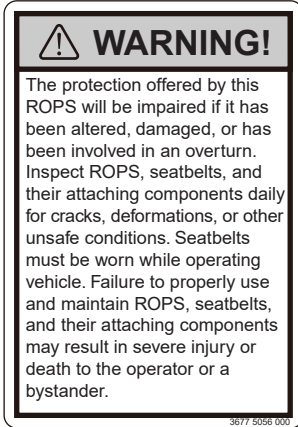

⑧ 3677 5045 001



⑨ 36A4 5018 000



⑩ 3683 5025 001



⑪ 3677 5043 001



Safety Precautions

This section contains safety precautions to follow when operating and maintaining the machine. Read and understand the precautions in this section as well as throughout this manual and follow them when operating or maintaining the machine. Failure to follow safety precautions could result in property damage, serious injury or death to the operator or bystanders.

Training

All operators and mechanics should receive practical instructions from their employer or renter. Such instructions should cover the following issues:

- **It is essential to familiarize yourself with the controls, safety labels and the proper use of the machine.**
- **Never allow people unfamiliar with these instructions to operate or service the machine. Do not let anyone under 18 years of age to operate this machine. Local regulations may restrict the minimum age for operating the machine. Consult your local authority.**
- **The operator is responsible for the accidents or hazards caused to other people or their property.**
- **This machine has a riding capacity for one person only. Do not carry passengers other than the operator.**
- **Always keep in mind that care and concentration is required when working with ride-on machines.**
- **Loss of control on a slope cannot be regained by the application of the brake. The main reasons for loss of control are:**
 - **insufficient grip of tracks.**
 - **excessive speed.**
 - **misjudging of the ground conditions, especially slopes.**
 - **excessive load.**
 - **incorrect distribution of load.**

Preparation

WARNING

- **Fuel is highly flammable. See Checking and Filling Fuel, page 16, for important safety information on handling fuel.**
- **Always wear protective footwear, long trousers, hardhat, safety glasses and ear protection when operating or servicing the machine. Proper clothing will minimize the chance of injury. Do not operate the equipment if you have long hair, loose clothing, or jewelry; all of which may get tangled in the moving parts. Do not operate the machine barefoot or with open sandals.**
- **Prepare beforehand the working rules and procedures such as signaling and traffic control for the work place. Following such rules will reduce the risk of accidents.**
- **Never handle fuel or grease, service the engine, or recharge the battery in the presence of fire or spark.**
- **Perform the daily pre-startup inspection (see Preparation), pages 16 before starting the machine. Repair or replace damaged parts before starting the machine.**

Operation

This machine is intended for carrying sand and dirt. Carrying other materials may damage the machine. Avoid carrying liquid concrete. That will damage the machine.

The stability of the machine is affected by the speed, rate of steering, terrain and the load. Always pay close attention to these factors or a loss of control or tip over could occur, resulting in property damage, serious injury or death.

General Driving

- **Do not operate the engine in a confined space where dangerous carbon monoxide fumes can accumulate.**
- **Do not touch the engine, muffler or exhaust pipe while the engine is running or soon after it has stopped. These areas will be very hot and can cause burns.**

- Do not operate the machine under the influence of alcohol or drugs. Do not operate the machine when you are tired, ill, or not feeling well.
- Always check for obstacles before operating on new terrain.
- Before starting the engine and moving the machine, scan around your surroundings and make sure all persons and other vehicles are a safe distance away from the machine. Sound the horn to warn bystanders.
- On the machine equipped with the ROPS, always wear the seat belt when in use.
- Always stay seated in the operator's seat when driving the machine. Never operate the drive lever off of the machine.
- On a slippery surface, travel slowly and exercise caution to reduce the chance of skidding or sliding out of control. Never operate on ice.
- Always make certain that there is no obstacle or a person behind the machine when backing up. After confirming that it is safe to back up, move slowly and avoid sharp turns.
- To reduce the risk of tip over, pay special attention when encountering an obstacle or a slope, or when braking on a slope or during a turn. See Driving on a Slope on the next page.
- Never attempt to drive over a large obstacle such as rock or fallen tree.
- Always travel slowly and use extra caution when operating on unfamiliar terrain. Be alert when traveling on changing terrain.
- Never operate on terrain that you are not comfortable with. Avoid terrain that is so rough, slippery or loose that you feel like you could tip over.
- Do not operate the machine near the edge of a cliff, an overhang or a slide area.
- Do not make sudden maneuvers. A sudden start, stop, or turn can make the machine lose control and could cause a tip over. Be especially cautious when traveling on soft or wet ground.

- Drive at a safe speed, taking into account the surface gradient, surface conditions and load.
- Use an observer to help direct the machine when the visibility is poor, terrain is rugged or hilly, or maneuvering room is limited. The observer should be able to see the machine and its immediate surroundings, and should give pre-arranged signals to direct the operator.

Driving on a Slope

WARNING

- Never use on a slope steeper than 20 degrees.
 - Driving on a slope can be dangerous. It can result in a tip over and cause serious injury or death. Take the following precautions.
- Always follow proper procedures for driving on a slope as described in this manual.
 - Driving on a slope in a wrong manner can cause a loss of control or a vehicle tip over. Check the terrain carefully before attempting to drive on a slope.
 - Never drive on a slope that you are not comfortable with. Avoid a slope that is so rough, slippery, or loose that you feel like you could tip over.
 - When driving up a slope, proceed at a steady rate of speed and throttle position.
 - Never move the throttle lever or the control lever suddenly.
 - If the engine stalls or loses traction during a climb and cannot make it to the top of the slope, do not try to turn the machine around. Carefully back down slowly, straight down the slope.
 - Drive straight up or down slopes. Avoid turning on a slope.
 - When going over the top of a slope, go slow; an obstacle, a sharp drop, or another vehicle or person could be on the other side of the crest.

- **Avoid driving the machine across a slope.**
- **Without a load, drive the machine backwards up a slope (operator's seat toward the top) when climbing, and drive it forward when going down a slope.**
- **With a load, drive the machine forward up a slope (operator's seat away from the top) when climbing, and drive it backwards when going down a slope. Be especially cautious when operating on a slope with a load.**
- **When driving down a slope, use the drive levers so that the machine travels down at the minimum speed. Use the engine speed to help keep the machine speed low.**
- **Do not use this machine in puddle or mud deeper than its ground clearance. Water or mud can enter the exhaust pipe or electrical components and damage the machine.**
- **Wash the machine after use in wet or muddy condition and grease up the grease points.**

Loading and Driving with a Load

- **The maximum payload for this machine is 11.8kN (1200kg). Do not exceed this maximum payload under any circumstance.**
- **Do not operate on a slope steeper than 20 degrees when carrying a load. Do not carry more than 600 kg when operating on a slope between 15 and 20 degrees.**
- **Load cargo in the bucket so the weight is evenly distributed. When carrying a cargo, strap the cargo to the bucket to prevent the cargo from shifting. Ensure that cargo does not obstruct the operator's field of view.**
- **When carrying a load, drive at a reduced speed. Allow a greater distance for braking.**
- **Before crossing a bridge or an overpass, make certain that the total combined weight of the machine, the load and the driver is within the stated weight limit for the bridge or the overpass. Then, proceed carefully and at a constant speed.**

Dumping/Turning

When swiveling the bucket and dumping material from the bucket, take the following precautions.

- Always follow the proper procedures for dumping or swiveling as described in this manual.
- Only operate the bucket with the engine running.
- Always stay seated in the operator's seat when dumping or swiveling the bucket. Never operate the dump or swivel lever off of the machine.
- Perform the dump operation on a flat, level and stable surface whenever possible. Raising or lowering the bucket on a slope or rough terrain could result in a tip over.
- Pay special care when dumping with the bucket swiveled to a side. Be tentative when raising the bucket which is swiveled to a side.
- Make certain that all persons are at a safe distance away from the machine when raising, lowering, or swiveling the bucket.
- Do not move the machine or leave it unattended with the bucket in the raised position.
- Engage the bucket safety prop if you must place any part of your body under the bucket in the raised position.

Parking

- Park the machine on a flat, level and stable surface. Never park on a slope steeper than 15 degrees. Avoid parking on a slope less than 15 degrees. If parking on a slope less than 15 degrees is unavoidable, swivel the bucket straight, apply the parking brake and block the tracks at the lower end of the machine.
 - Without a load, park the machine with the operator's seat facing downhill
 - With a load, park the machine with the operator's seat facing uphill
 - Do not park sideways on a slope.
- Observe all the previous precautions for driving, driving on a slope, loading and driving with a load, and dumping.

- Whenever you park the machine, apply the parking brake and stop the engine. Remove the key whenever you leave the machine unattended to prevent unauthorized use or accidental starting.
- Diesel fuel is flammable and can be explosive. When parking the machine indoors, make certain that the building is well ventilated and that the machine is not close to any source of flame or spark, including appliances with pilot lights.

Servicing

- Do not service the machine when the engine is running. If it is absolutely necessary to run the engine while servicing, pay attention to the moving parts; keep hands, feet, clothing and any part of the body away from any moving part, especially the cooling fan and the belts at the side of the engine.
- Do not operate the engine in a confined space where dangerous carbon monoxide fumes can accumulate.
- Make sure all hydraulic line connectors are tight and all hydraulic hoses and lines are in good condition and leak-free before applying hydraulic pressure to the system.
- Keep your body and hands away from pinhole leaks or nozzles that eject hydraulic fluid under high pressure. Use paper or cardboard, not your hands, to search for leaks. Hydraulic fluid escaping under pressure can have sufficient force to penetrate the skin and cause serious injury.
- Check all fuel lines on a regular basis for tightness and wear. Tighten or repair them as needed.
- Do not touch the engine, muffler, or exhaust pipe while the engine is running or soon after it has stopped. These areas will be very hot and can cause burns.
- The engine must be shut off before checking or adding oil.

Name and Function of Controls

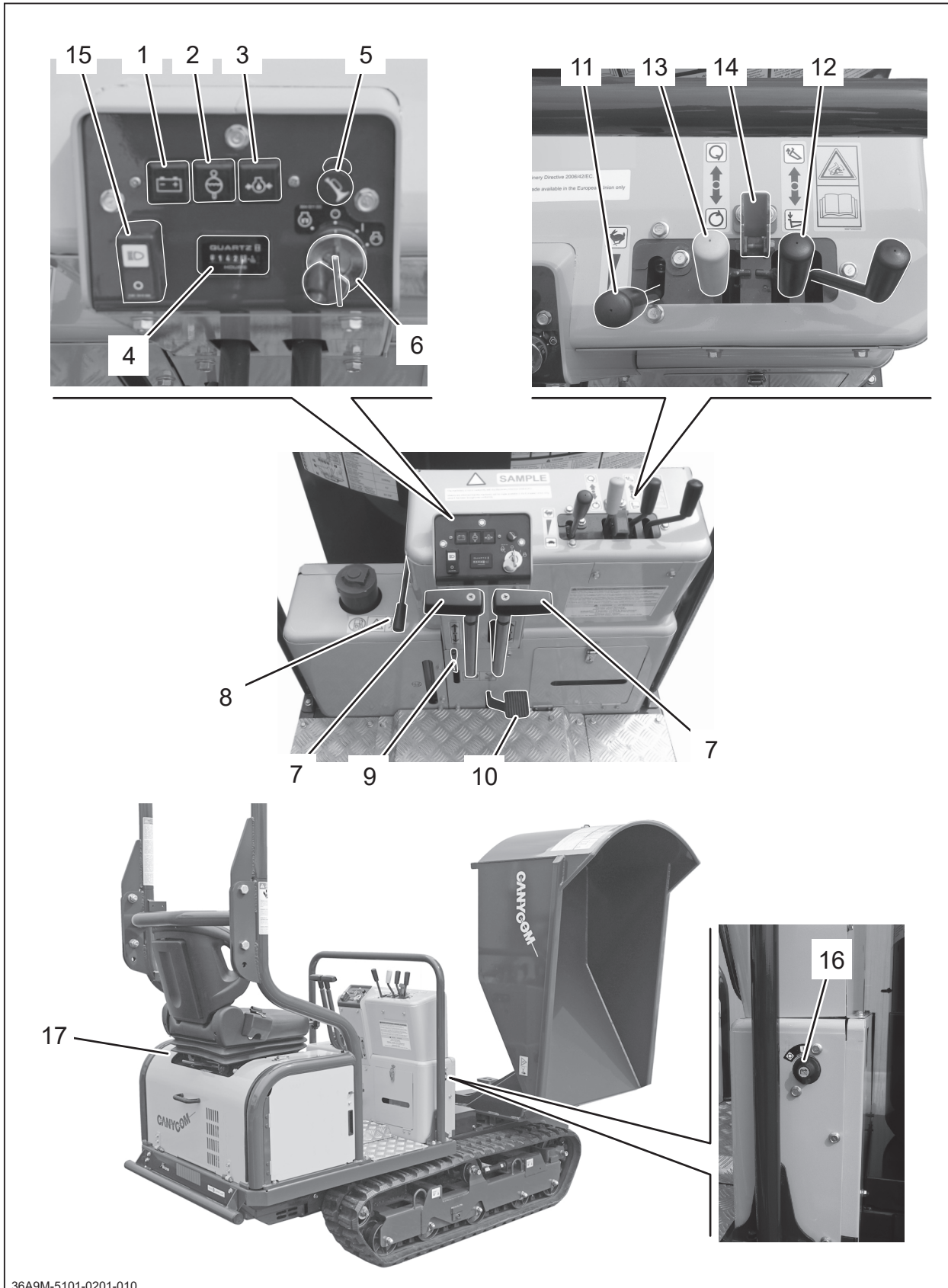





36A9M-5101-0201-010

2

Controls and Components

1. **Charge Warning** This shows if the battery is being charged. It turns on when the main switch is turned on, and under normal condition, it goes off once the engine starts.
2. **Overheat Warning** This lights up when the engine coolant temperature goes up abnormally.
3. **Oil Pressure Warning**. This warns low engine oil pressure. It turns on when the main switch is on and the engine is not running. Once the engine starts, it goes off. If it stays on while the engine is running, oil pressure is low; stop the engine immediately.
4. **Hour Meter** Hour meter indicates the cumulative total operating time of the machine in 0.1 hour increments.
5. **Horn Button** Pressing this switch sounds the horn.
6. **Main Switch** This is used to start or stop the engine.
7. **Drive Lever** This is used when changing the direction of travel (FORWARD or REVERSE) or when turning the machine.
8. **Clutch Lever** This is used when it is difficult to start the engine in cold weather.
9. **Parking Brake Lock Lever** Parking brake lock lever is used when parking the machine securely. Pulling the parking brake lock lever while the parking brake pedal is depressed locks the parking brake pedal in the engaged position.
10. **Parking Brake Pedal** Parking Brake pedal is used to keep the machine from moving.
11. **Throttle Lever** This increases or decreases the engine speed.
12. **Dump Lever** This is used to raise or lower the dump body.

- 13. **Swivel Lever** This lever is used to swivel the dump body.
- 14. **Lock Plate** This is used to lock the dump and swivel lever.
- 15. **Light Switch** Pressing  button turns the head lights on. Pressing the  button turns off the head lights.
- 16. **Battery Cut Off Switch** This switch cuts off the battery's negative terminal for service or long-term storage. Turning it to  connects the terminal. Turning it to  disconnects.
- 17. **Seat Lock Lever** Pulling the seat lock lever unlocks the seat for service.

Product Specifications

⚠ CAUTION

· Use this product properly after understanding its specifications thoroughly.

Model and Type			S100B	
			Swivel Dump (scoop bucket)	
Machine Mass		kg (lbs)	1100 (2447)	
Maximum Payload		kN (lbs)	11.8 (2646)	
Dimensions	Overall Length		mm (in)	2670 (105.1)
	Overall Width		mm (in)	990 (39.0)
	Overall Height		mm (in)	2330 (91.7)
	Tumbler Length		mm (in)	1160 (45.7)
	Track Tread		mm (in)	760 (29.9)
	Minimum Ground Clearance		mm (in)	145 (5.7)
	Floor Height		mm (in)	620 (24.4)
Loading Deck	Inside Dimensions	Length	mm (in)	1340 (52.8)
		Width	mm (in)	890 (35.0)
		Height	mm (in)	490 (19.3)
	Payload	Struck	m ³ (cu ft)	0.39 (13.8)
		Heaped	m ³ (cu ft)	0.59 (20.8)
Engine	Model		Kubota D 902	
	Type		4-cycle, Water-cooled Diesel	
	Cylinder (Bore×Stroke)		mm (in)	72 X 73.6 (2.83 X 2.90)
	Total Displacement		cm ³ (cu in)	898 (54.8)
	Rated Output		kw(HP)/rpm	13.2 (17.7) / 2600 *net *1
	Maximum Torque		N•m(lbf•ft)/rpm	53.5 (39.5) / 2200 *net *1
	Starting		Electric	
	Fuel used		Diesel Fuel	
	Fuel Consumption		g/kW•h(oz/PS•h)	271 (7.0)
	Fuel Tank Capacity		L (US gal)	15.0 (4.0)
	Lubricating Oil Capacity		L (US qt)	3.7 (3.9)
	Battery Type		75D23R	
	Battery Capacity		V/AH	12/52
Performance	Travel Speed		km/h (mph)	0 to 5.6 (0 to 3.5)
	Minimum Turning Radius		m (ft)	1.55 (5.1)
	Gradability		Degrees	25 (unloaded)

*1 As per ISO 14396:2002

Model and Type			S100B	
			Swivel Dump (Scoop Bucket)	
HST Oil Capacity		L (US gal)	20 (5.3)	
Drive Train	Main Transmission		Twin HST	
	Steering System		Twin HST - 2 Lever	
	Brakes		Internally Expanding	
Dumping System	Dump System		Swivel Dump	
	Hydraulic Pump	Type	Gear Pump	
		Max. Speed	rpm	2,500
		Max. Discharge	L / min (US qt / min)	10.0 (10.5)
	Relief Pressure		MPa(psi)	14.2 (2060)
	Cylinder(Bore X Stroke)		mm (in)	60 X 400 (2.4 X 15.7)
	Performance	Max. Angle	Degrees	90
		Lifting Time	Sec	approx. 6.5
		Lowering Time	Sec	approx. 4.0
Hydraulic Fluid Capacity		L (US gal)	Shared with HST System	
Swivel System	Swivel System		Hydraulic (Twin cylinder)	
	Swiveling Angle		°	90(Right) - 90 (Left)
	Swiveling Time		Sec	approx. 3.0 (90°)
	Cylinder(Bore X Stroke)		mm (in)	50 X 160 (1.97 X 6.30)
Operating Temperature		°C (°F)	between -15°C and +40°C (5°F and 104°F)	
Operating Elevation		m (yd)	below 1500 *2 (1640)	

*2 Engine performance is reduced when used above 1500m (640 yd) of elevation.

These specifications are subject to change without notice.

Contents of Tool Bag

No.	Content	Quantity	Note
1	Operator's Manual	1	This Manual
2	Engine Manual	1	
3	Grease Nipple	1	M6

Preparation

Pre-start up Inspection

Always perform an inspection before use.

Refer to **Maintenance Schedule** (page 32) for the inspection schedule and procedure.

Checking and Filling Fuel

⚠ WARNING

- Keep fire and spark away when handling fuel.
- Always stop the engine before refueling.
- Do not overfill fuel above the limit (the bottom of the fuel filler filter) so that fuel will not overflow. In case fuel is spilt, wipe out immediately.

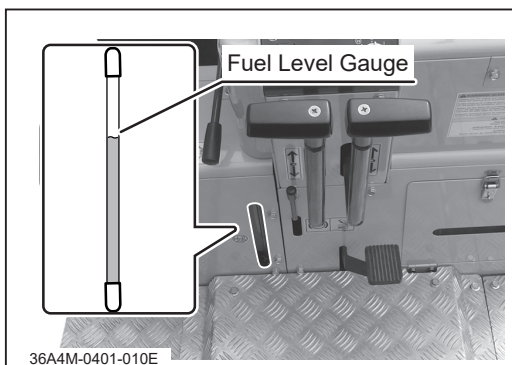

Checking Fuel

1. Visually check the fuel level gauge. If the fuel level is low, fill fuel.

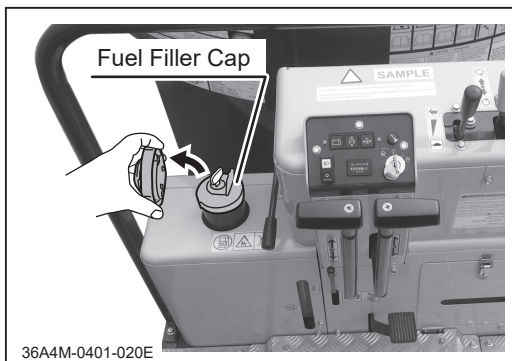

Filling Fuel

1. Unlock the fuel filler cap with the key.
2. Remove the fuel filler cap and fill fuel.
3. Replace the fuel filler cap and close it securely.
4. Lock the fuel filler cap.

NOTE

- Fuel : Diesel Fuel.
- Fuel Tank Capacity : 15L (4.0 US gal.)

Adjusting Seat

⚠ WARNING

- When adjusting the seat, make certain the seat is securely locked.
- On the machine equipped with the ROPS, Always wear the seat belt.

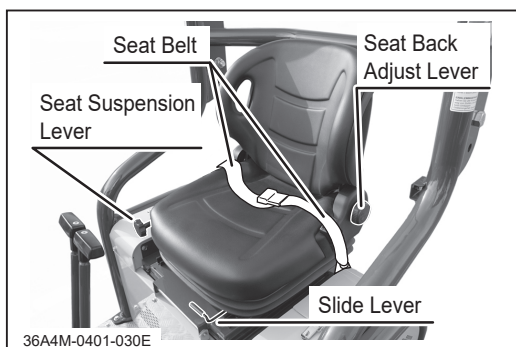

Adjusting seat

1. Pull the seat slide lever up to slide the seat to a desired position.
2. Turn the seat back adjust lever to the right to adjust the seat back to a desired position.
3. Turn the seat suspension knob to adjust the firmness of the seat suspension to suit the operator's weight and preference.

Buckling seatbelt

1. Adjust the seat belt so that it holds the pelvis snugly. Buckle the seatbelt.

Driving

Starting

WARNING

- Always start and run the engine in a well ventilated place.
- Always make certain of the safety of your surroundings and stay on the seat when starting the engine.
- Never attempt to start the engine away from the machine. Run over accident can result.
- An engine that has been running is very hot. Avoid touching the engine and its ancillaries, or severe burns may result.
- Do not open the engine hood while the engine is running.

CAUTION

- Do not turn the starter when the engine is running. Starter motor and/or the engine may be damaged.
- Do not turn the starter for more than 10 seconds. If the engine does not start, turn it back to the [ (off)] position and wait for 30 seconds or more before attempting to start again.
- Do not use this machine in the temperatures above 40°C or below -15°C. This machine cannot perform adequately in these temperature ranges. Using this machine under such conditions may result in an accident or cause damage to the machine.
- In the winter or cold climate, warm up the engine thoroughly before driving the machine. A cold engine delivers poor performance, which can result in an accident. It also causes premature wear.

⚠ CAUTION

- Do not use this product in dusty places such as desert. Dust may clog the air cleaner or enter the engine, which may result in loss of performance and an accident. It also causes premature wear.
- Do not use this machine in the altitude above 1500m in its original configuration. This machine cannot perform adequately above that altitude. Using this machine under such conditions can result in an accident or cause damage to the machine. If you need to use this machine above that altitude, contact your CANYCOM representative.

NOTE

- Preheat the glow plug for about 5 seconds when starting in normal temperature and for 10 to 20 seconds when starting in cold weather (ambient temperature below 0°C).
- Preheating is not necessary when engine is already warm.
- Drive machine gently in the first 40 to 50 hours of use after purchase for breaking-in.

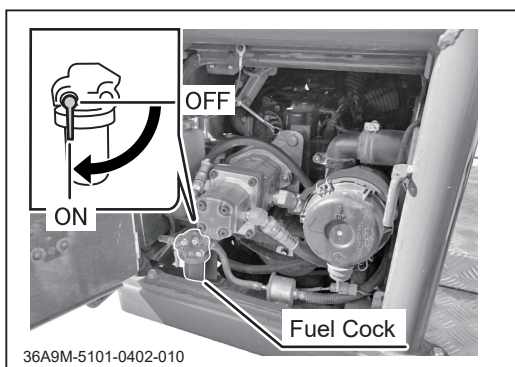

Preperation

1. Open the right-hand side engine cover.
2. Turn the fuel cock to [ON] position.

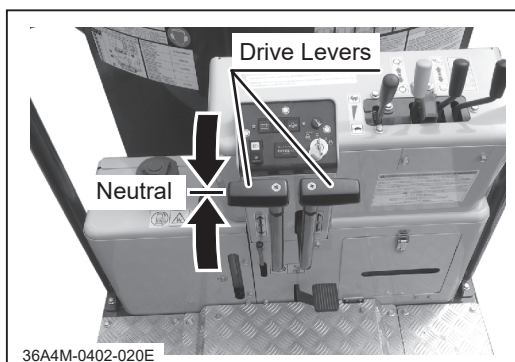

3. Make sure the drive levers are in the neutral position.

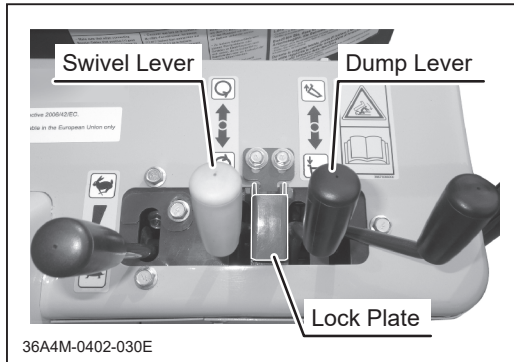

4. Make sure the dump and swivel levers are in the neutral position and locked with the lock plate.

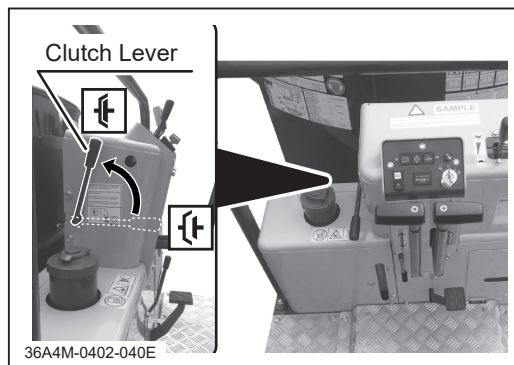

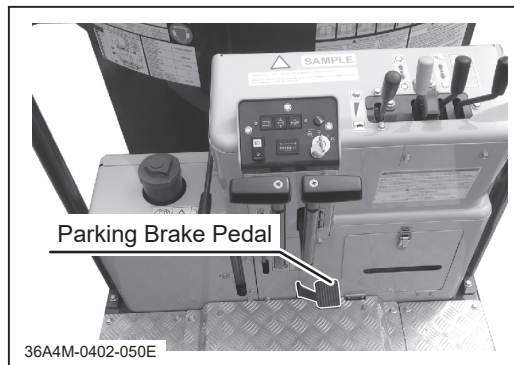

Starting

1. Move the clutch lever to [ (engaged)] position.

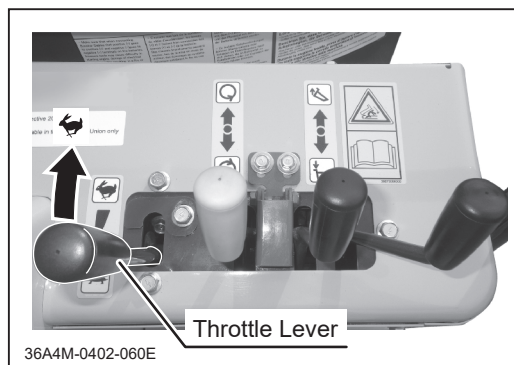

2. Press down the parking brake pedal fully.



3. Move the throttle lever half way toward the [ (fast)] position.

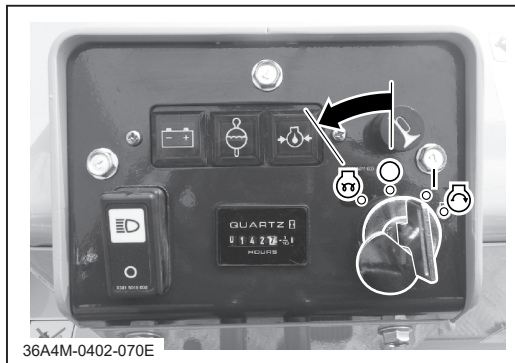

4. Insert the key into the main switch and Turn it to the [ (preheat)] position to heat up the glow plug for 5 seconds.

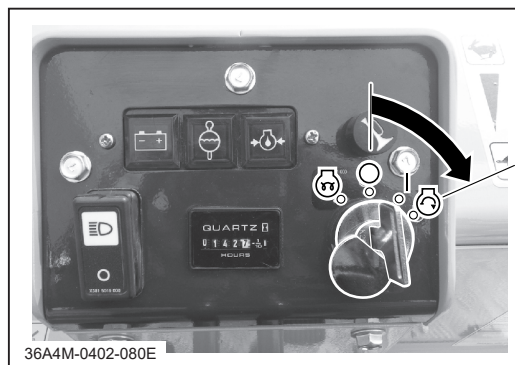

5. Turn the main switch to the [ (start)] position to start the engine. Once the engine starts, release the key immediately; switch will automatically return to the [| (on)] position.

NOTE

- **Avoid frequent restarting. Once the engine starts, run it for a while to charge the battery**

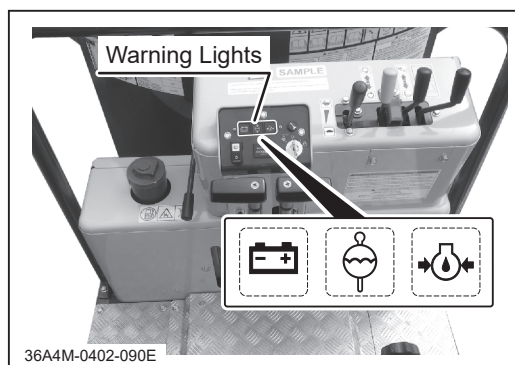

6. Make certain the warning lights (charge, overheat, oil pressure) are not lit.





NOTE

- **Warning lights turn off once the engine starts. If any of the warning lights remains lit, stop the engine immediately and refer to the Troubleshooting (page 71) to take an appropriate measure.**

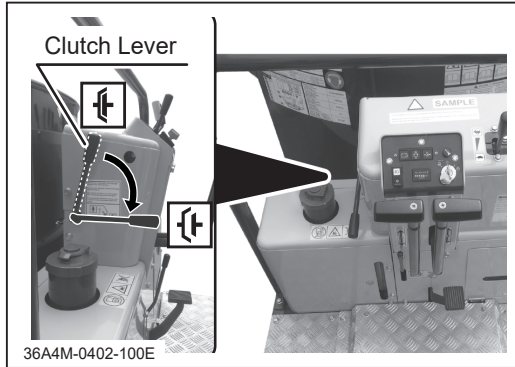
Starting in Cold Weather

When the machine is difficult to start under cold weather, follow the procedure below.



1. Move the clutch lever to [ (disengaged)] position.
2. Press down the parking brake pedal fully.
3. Move the throttle lever half way toward the [ (fast)] position.
4. Insert the key into the main switch and Turn it to the [ (preheat)] position to heat up the glow plug for 10 to 20 seconds.
5. Turn the main switch to the [ (start)] position to start the engine. Once the engine starts, release the key immediately; switch will automatically return to the [| (on)] position.

NOTE

- **Avoid frequent restarting. Once the engine starts, run it for a while to charge the battery**

6. Make certain the warning lights (charge, overheat, oil pressure) are not lit.

NOTE

- **Warning lights turn off once the engine starts. If any of the warning lights remains lit, stop the engine immediately and refer to the Troubleshooting (page 71) to take an appropriate measure.**

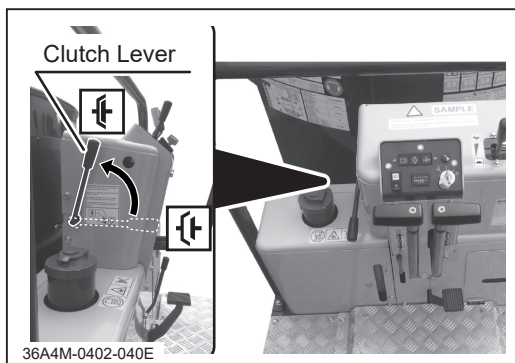

7. Move the clutch lever to [ (engaged)] position.
8. Run engine for about 5 minutes without load to warm up.

Driving

WARNING

- Do not allow bystanders to come near the machine when driving.
- Always stay seated in the operator's seat when driving the machine. Never operate the drive lever off of the machine. This can cause the machine to run over or crush the operator.
- Always wear the seat belt.
- Always make certain of the safety of your surroundings before driving. Start slow. Drive at a safe speed, depending on the condition and gradient of the ground. Always make certain of the safety of your surroundings before turning
- Do not make sudden starts, acceleration, change of speed, change of direction, or stop. Do not turn at speed. Avoid sudden maneuvers; this can cause the operator to fall, to be thrown, or the machine to tip over.
- Do not turn the key to the [○ (off)] position while traveling. Machine can lose stability and cause the operator to fall, to be thrown, or the machine to tip over.
- Always move the drive levers back to the neutral position before releasing. Letting it go from other operating positions can result in sudden deceleration and can cause the machine to tip over or the operator to fall or to be thrown.
- Do not drive the machine with its bucket in raised position. Tipover can result.
- Drive carefully on slope. Drive slow. Do not turn on slope. Do not cross slope steeper than 10°. Machine can slip or tipover.
- Have a conductor to help guide the machine in the terrain that is narrow, rough, steep, or with low visibility.

⚠ CAUTION

- Hold the grips when operating the drive levers. Fingers or hands can get caught if holding other parts to operate.
- Do not operate the drive levers with brake pedal depressed or locked. Doing so will sound the horn to warn the operator.

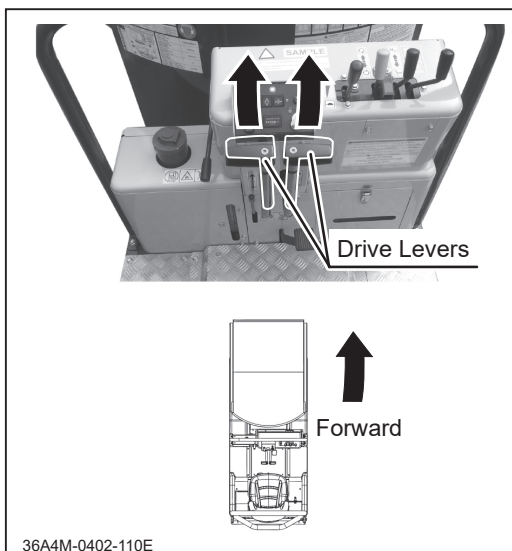
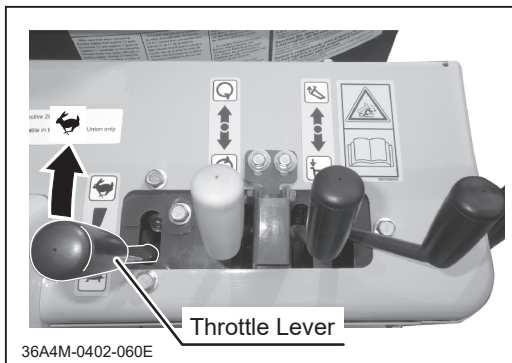
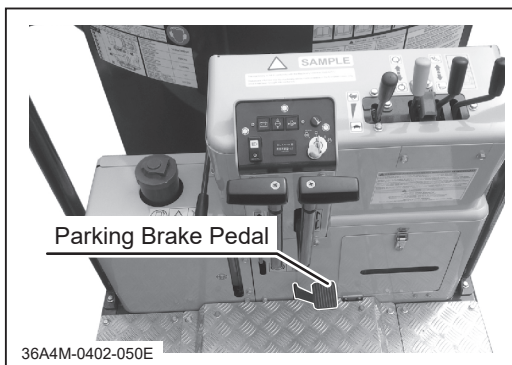

Preparation

1. Make certain of the safety of your surroundings.
2. Depress the parking brake pedal and move the parking brake lock lever up to release the parking brake.
3. Move the throttle lever toward the [ (fast)] position to increase engine speed.

Moving Forward

4. Move the left and right drive levers gradually forward together to move the machine forward. The angle of the drive levers controls the machine speed.

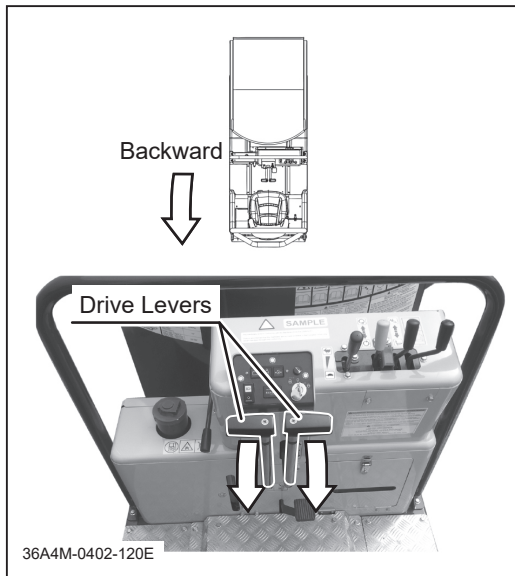

Moving Backward

5. Move both of the drive levers gradually backward together to move the machine backward. The angle of the drive levers controls the machine speed.

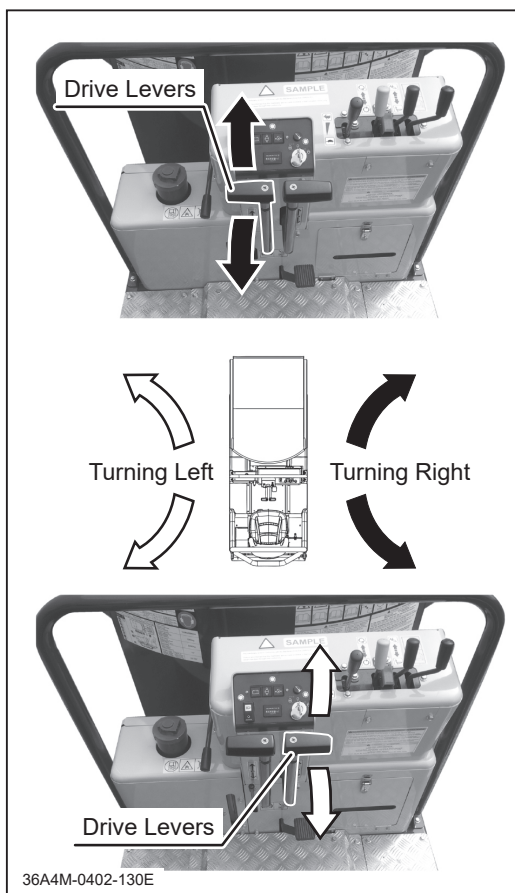

Normal Right Turn

6. To turn right when traveling forward, push left drive lever slowly forward.
7. To turn right when traveling backward, push left drive lever slowly backward.

Normal Right Turn

6. To turn left when traveling forward, push right drive lever slowly forward.
7. To turn left when traveling backward, push right drive lever slowly backward.

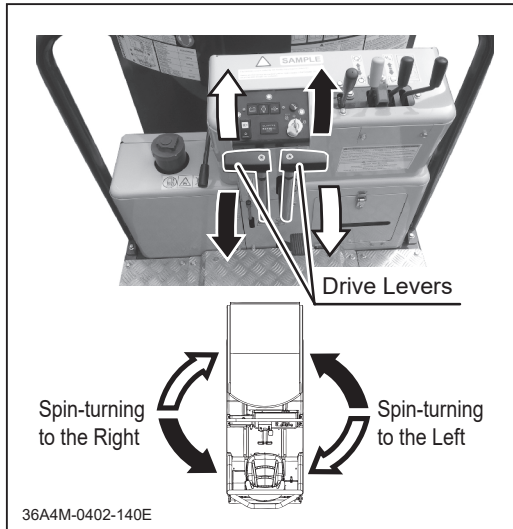

Spin Turn

8. Move drive levers in opposite directions to make a turn on spot (spin-turn).

Stopping and Parking

⚠ WARNING

- Do not make a sudden stop. The machine can skid or tip over.
- Do not release the drive levers suddenly. The machine can stop suddenly and skid or tip over.
- Always park on a firm, level place. Never park on a potentially dangerous place.
- Avoid parking on a slope. Never park on a slope with an incline of 15 degrees or steeper. If it is absolutely necessary to park the machine on a slope less than 15 degrees, make certain to apply parking brake firmly and block the tracks with chocks.

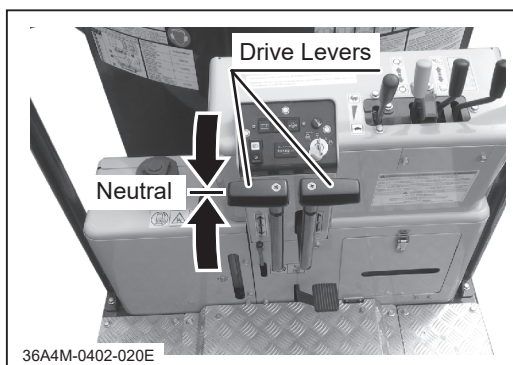

1. Move the drive levers gradually to the neutral position.
2. Depress the parking brake pedal.

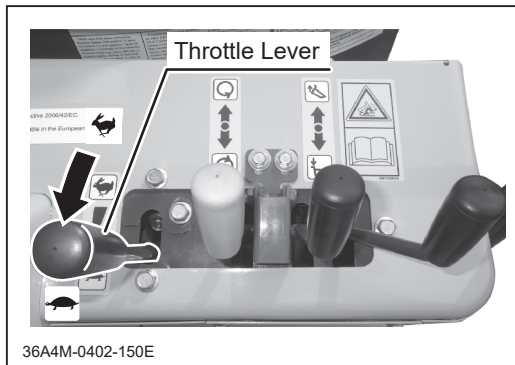

3. Push the throttle lever to [ (slow)] position to lower engine speed.

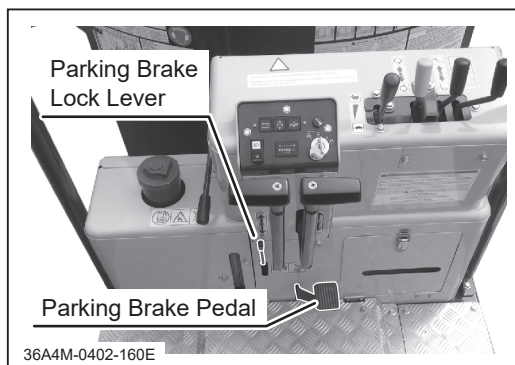

4. With the parking brake pedal depressed, pull out the parking brake lock lever to lock the parking brake.

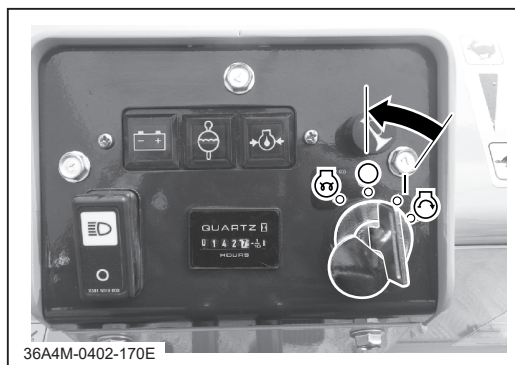

5. Turn the main switch to [ (off)] position and remove the key from main switch. Get off of the machine.

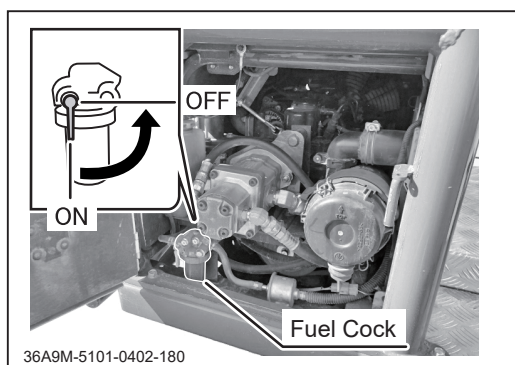

6. Open the right-hand side engine cover.
7. Turn the fuel cock to [OFF] position.
8. Close the right-hand side engine cover.

Working

⚠ WARNING

- Always make certain of the safety of your surroundings when dumping or swiveling bucket.
- Never drive the machine with the bucket in the raised or swiveled position. Tipover can result as the center-of-gravity shifts. Also, doing so can increase the possibility of hitting objects with the raised or swiveled bucket.
- Never operate the dump or swivel lever off of the machine. This may cause the bucket to hit or crush the operator or bystander.
- Avoid dumping or swiveling the bucket on slope. The machine can tip over.

⚠ CAUTION

- Always run the engine when dumping or swiveling bucket.
- When lowering the loaded bucket, slow the engine speed and lower the bucket gently.

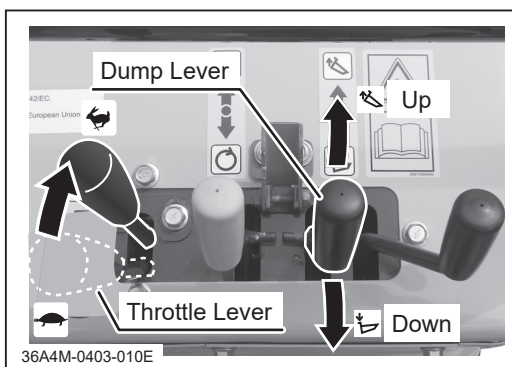

Dumping



Raising the Bucket

1. Start the engine and move the throttle lever to the [⚡ (fast)] position to increase the engine speed.
2. Flip the lock plate to the side so that the dump lever can be operated.
3. Move the dump lever gradually toward the [⬆ (up)] position to raise the bucket.
4. When the bucket reaches its upper limit, a hissing noise is heard; move the dump lever back to [● (neutral)] position.

Lowering the Bucket

1. Flip the lock plate to the side so that the dump lever can be operated.
2. Move the dump lever gradually toward the [ (down)] position to lower the bucket.
3. When the bucket reaches its lower limit, a hissing noise is heard; move the dump lever back to [ (neutral)] position.
4. Flip the lock plate over the dump lever.

Swiveling Bucket

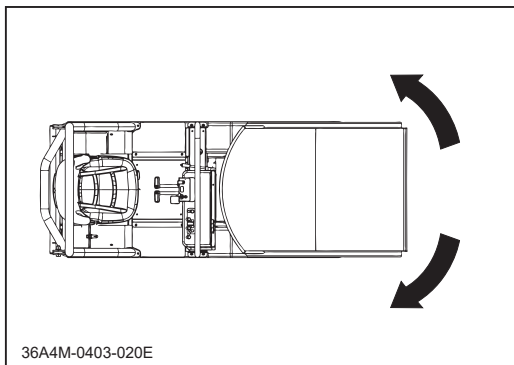



Swiveling to the Left

1. Flip the lock plate to the side so that the swivel lever can be operated.
2. Move the swivel lever gradually toward [ (left)] to swivel the bucket to the left.

NOTE

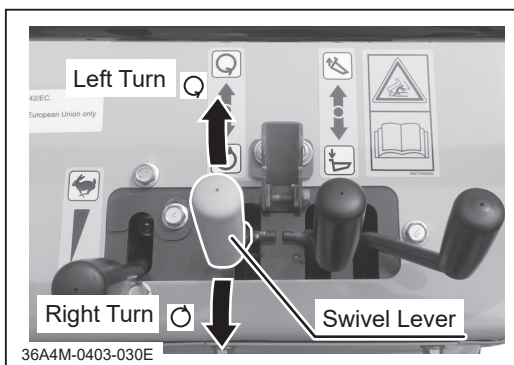
- **Maximum swiveling angle: 90° (left and right)**



3. When the bucket reaches its limit, a hissing noise is heard; move the swivel lever back to the [ (neutral)] position.
4. When keeping the bucket at the swivelled position, flip the lock plate over the swivel lever.

Swiveling to the Right

5. Flip the lock plate to the side so that the swivel lever can be operated.
6. Move the swivel lever gradually toward [ (right)] to swivel the bucket to the right.

7. When the bucket reaches its limit, a hissing noise is heard; move the swivel lever back to the [● (neutral)] position.
8. When keeping the bucket at the swivelled position, flip the lock plate over the swivel lever. Otherwise, Move the swivel lever gradually toward [◀ (left)] until the bucket reaches to the neutral and flip the lock plate over the swivel lever.

Using Safety Prop

⚠ WARNING

- Place the safety prop under the bucket when inspecting or working under the bucket.

⚠ CAUTION

- Make certain to undo the safety prop before lowering the bucket.

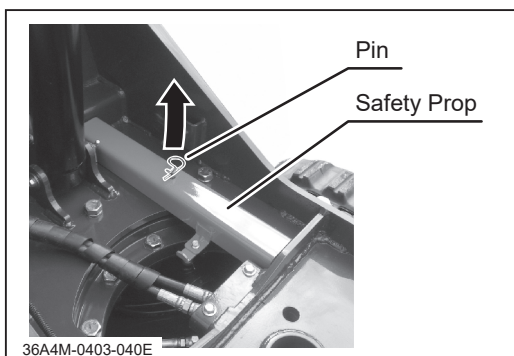

1. Raise the bucket.
2. Remove the pin holding the safety prop and remove the safety prop.

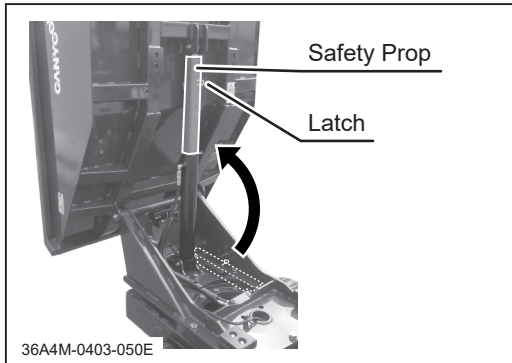

3. Place the safety prop over the piston rod of the dump cylinder.
4. Turn the latch on the safety prop to secure it onto the piston rod.

Maintenance Schedule

⚠ WARNING
<ul style="list-style-type: none"> • Follow the scheduled maintenance as described below. Failure to do so may result in mechanical or property damage, injury or death.

- Perform a pre-startup inspection (PSI) before each use, a monthly inspection once a month, and a yearly inspection once a year.
- Some maintenance procedures described below may require special knowledge or tools and instruments. Contact your CANYCOM representative to perform such procedures.

	Item	Description	Schedule			Note
			PSI	Mon	Year	
Engine	Starting	Engine shall start easily without making any irregular noise.	√	√	√	
		Glow plugs work correctly.	√	√	√	
	Running	Engine speed shall be set properly at idle and at full without loading. Engine shall stay running smoothly.	√	√	√	Contact your CANYCOM representative for inspection.
		When accelerating engine, throttle lever shall move smoothly, and engine shall accelerate smoothly without stopping or knocking.	√	√	√	
	Exhaust	Warm up engine thoroughly and observe exhaust sound and gas from idle to fast speed; exhaust sound shall be normal and smoke shall not be excessive.	√	√	√	
		There shall be no leak in exhaust system or muffler.	√	√	√	
	Air Cleaner	Air cleaner case shall not be deformed or cracked. Case lid and connecting air hose shall be firmly in place.		√	√	
		Cleaner element shall be in good shape without damage or excessive dust.	√	*	*	
	Fasteners	Bolts and nuts fastening cylinder head, intake and exhaust manifolds shall be tightly fastened. * this may be skipped if there is no gas or water leaks found in these areas.			√	

* Refer to the separate manual for the engine.

Item	Description	Schedule			Note			
		PSI	Mon	Year				
Engine	Compression	Compression shall be normal * this may be skipped if running and exhaust condition is normal at idle and under acceleration.			√	Contact your CANYCOM representative for inspection.		
	Engine Mount	Engine base shall be free of cracks or deformation.			√			
		Mounting bolts and nuts shall not be loose or missing.			√			
	Lubrication System	Oil shall be clean and at correct level.			√	√	√	Inspecting/Changing: Page 41
		No noticable oil leaks shall be found in head cover, oil pan, or pipes.			√	√	√	
		Oil filter shall not be excessively dirty or clogged.					√	Changing:Page 43
	Fuel system	There shall not be any leaks in fuel tank, injection pump, hoses, or pipes.			√	√	√	
		Fuel hoses shall be free of damage or deterioration.			√	√	√	
		Fuel filter or water separator shall not be excessively dirty or clogged. There shall not be excessive water in the water separator.				√	√	
		There shall not be sediment or water in fuel tank.				√	√	
		Injection puessure and injection condition from the nozzle shall be normal. * this may be skipped if running and exhaust condition is normal at idle and under acceleration.					√	Contact your CANYCOM representative for inspection.
	Cooling System	Coolant shall be clean and at the correct level.			√	√	√	Inspecting: Page 46
		There shall not be any leaks from radiator, engine, water pump, or hoses.			√	√	√	
		Radiator fins shall be free of clogging or blocking.			√	√	√	
		Hoses shall be free of damages or deterioration.			√	√	√	
		Radiator cap valve shall function properly.					√	

Item	Description	Schedule			Note	
		PSI	Mon	Year		
Engine	Cooling System	Radiator cap valve seat shall be free of damages.			√	
		Fan belt shall be properly tensioned.			√	Inspecting/Adjusting: Page 47
		Fan belt shall be free of wear and damage.			√	
		Cooling fan, duct, and cover shall be free of cracks, damage, or deformation.			√	
		Mounting bolts and nuts on cooling fan, duct, and covers shall not be loose or missing.			√	
Electrical	Charge System	Charge system shall work properly.			√	Contact your CANYCOM representative for inspection.
	Battery	Battery electrolyte level shall be within the correct range.		√	√	Inspecting/Filling: Page 63
		Terminals shall be free of marked corrosion and are tightly secured.		√	√	
	Wiring	Connections shall be securely connected.		√	√	
		Wiring shall be free of damages.		√	√	
Drive Train	Drive Belt	Belt shall be free of damage, excessive wear, or dirt; shall be free of oil or grease.		√	√	
		Belt tension shall be properly adjusted.		√	√	
	HST Pump	Drive the machine forward and backward, turn left and right in both directions; machine shall move normally and free of irregular noise or overheating.	√	√	√	
		Hydraulic fluid shall be filled to a proper level.		√	√	Inspecting/Changing: Page 51
		Hydraulic fluid shall be clean and free of dirt or contamination.		√	√	Inspecting/Changing: Page 51
		There shall be no fluid leaks in or around fluid tank.		√	√	
Undercarriage	Rollers Sprockets Idlers Upper Rollers	Shall be free of cracks, defromation, or excessive wear.	√	√	√	
		There shall not be excessive play in axle.				
		Irregular noise or overheating shall not be observed when traveling.	√	√	√	
		Mounting bolt or nut shall not be loose or missing.	√	√	√	
		There shall be no oil leak in or around axle.	√	√	√	

Item	Description	Schedule			Note	
		PSI	Mon	Year		
Undercarriage	Tracks	Steel cord of the track shall not be cut or severely damaged.	√	√	√	
		Track shall not be excessively worn, or deteriorated. There shall not be a big chunk of rubber missing.	√	√	√	
		Steel core inside the track shall not be damaged or missing.	√	√	√	
		Track shall be properly tensioned; shall not be too loose or too tight.	√	√	√	Adjusting: see Page 56
	Track Tensioner	Tension bolt shall be free of deformation or corrosion.		√	√	
	Track Frame	There shall not be cracks, deformation, damage. If a crack is suspected, check it with crack detector.		√	√	
Mounting fasteners shall not be loose or missing.		√	√	√		
Brake	Parking Brake	Parking brake shall work properly.	√	√	√	Adjusting: see Page 61
		Parking brake shall be able to hold the machine on a 1/5 slope.		√	√	
Hydraulic System	Hydraulic Pump	There shall be no leak in or around hydraulic pump, hose, joints, or seals.	√	√	√	
		No irregular vibration, noise, or heat shall be observed when hydraulic pump is in operation.	√	√	√	
		Amount and pressure of discharge under load shall be within the standard range specified by the manufacturer. *this may be skipped if irregular vibration, noise, or heat described above is not observed.			√	
	Plumbing (Hoses, High Pressure Pipes)	Plumbing shall be free of cracks, damage, twists, or deterioration.	√	√	√	
		There shall be no leaks in pipes, hoses, joints, or seals.	√	√	√	
		Plumbing shall be mounted properly, and fastening bolts and nuts shall not be loose or missing.	√	√	√	

Item	Description	Schedule			Note	
		PSI	Mon	Year		
Hydraulic System	Hydraulic Cylinders	Shall work smoothly.	√	√	√	
		There shall be no leaks when extending and contracting cylinder a few times.		√	√	
		Extend dump cylinder fully under load and hold. Drop shall be within the range specified by manufacturer.			√	
		Cylinder tube and rod shall be free of dents, cracks, bends, or scratches.		√	√	
		Cylinder mounting pins shall be free of damage or excessive wear.	√	√	√	
	Hydraulic Valve	Valve spool shall move smoothly.	√	√	√	
		Hydraulic valve shall be mounted properly.		√	√	
		When operated, valve shall extend or contract the cylinder, and stop it when released.	√	√	√	
There shall be no leak in or around hydraulic valve, plumbing , or joints.		√	√	√		
Body, Chassis, Vessel	Vessel (Bucket)	Vessel shall be raised,lowered and swiveled smoothly.	√	√	√	
		Shall be free of cracks, deformation, or corrosion.	√	√	√	
		Fastening bolts or nuts shall not be loose or missing.	√	√	√	
		Raise and lower vessel to make sure that there is no excessive play at the cylinder pin and dump pivot.		√	√	
	Safety Prop	Safety prop shall be installed securely.	√	√	√	
		Safety prop shall be free of any cracks, corrosion or deformation.	√	√	√	
		There shall not be any crack or deformation in the base of safety prop or stoppers.		√	√	
	Chassis Frame	Shall be free of cracks, deformation, or corrosion.		√	√	
		Fastening bolts or nuts shall not be loose or missing.	√	√	√	
	Body Panels	Shall be free of cracks or deformation.		√	√	
		Doors shall open, close, and lock properly.	√	√	√	
		Fastening bolts or nuts shall not be loose or missing.	√	√	√	

Item	Description	Schedule			Note	
		PSI	Mon	Year		
Body, Chassis, Vessel	Instruments	Instruments shall work properly once engine starts.	√	√	√	
	Meters					
	Horn	Horn shall work normally.	√	√	√	
	Lights	Lights shall work normally.	√	√	√	
	ROPS	ROPS shall be free of deformation or corrosion.	√	√	√	
		Mounting fasteners shall be secure and not missing.	√	√	√	
	Seatbelt	Mount shall not be loose.	√	√	√	
		Seatbelt shall be free of cuts or damages.	√	√	√	
Emergency Switch	Engine shall stop immediately once emergency switch is activated.	√	√	√		
Lubrication	Greasing and oiling points shall be sufficiently lubricated.		√	√	Lubricating: Page 39	
Overall	Drive the machine and operate the vessel to make sure all the functions perform normally without any abnormal sound, vibration, or heat.			√		

List of Fluids and Lubricants

⚠ CAUTION
<ul style="list-style-type: none"> • Follow the maintenance schedule to lubricate or grease the machine. Lack of lubrication can result in rust, excessive wear or seizure.

List of Fluids and Lubricants

Item	Schedule	Grade	Cap.
Fuel	As needed.	Diesel Fuel	15L (4.0 US gal)
Engine Oil	Fill Inspect daily. Fill as needed. Change Initially - After 50 hours of use. Every 100 hours afterwards.	Diesel Engine Oil API rating: CF SAE rating: 10W-30	3.7L (3.9 US qt)
HST Fluid (also used as hydraulic fluid)	Change Every 500 hours afterwards.	Wear resistant hydraulic fluid, VG32	20L (5.3 US gal)
Engine Coolant	Check Everyday Fill as needed Change every 2 years	Long Life Coolant (LLC) and pure water Mixture (50% dilution)	3.1L (0.8 US gal)
Battery Electrolyte	Inspect every 50 hours. Fill as needed.	Distilled Water	-
Transmission Oil	Change Initially - After 50 hours of use. Every 100 hours afterwards.	Gear Oil API grade: GL-4 or 5 SAE index: 80	2.0L (2.1 US qt)
Oiling Points	Once every 6 months. * Not necessary for the first 6 months after purchase.	Gear Oil API grade: GL-4 or 5 SAE index: 80	-
Greasing Points	Once every 6 months. * Not necessary for the first 6 months after purchase.	Chassis Grease	-

Greasing

NOTE

- When using a manual grease pump, push handle five to six times. When handle becomes heavy, stop pushing.
- When using a pneumatic grease pump, charge for two to three seconds.

	Location	Schedule	No. of Points	Grade
1	Parking Brake Pedal Link	Every 6 Months	1	Chassis Grease
2	Clutch Lever Pivot	Every 6 Months	2	Chassis Grease
3	Hydraulic Cylinder Pivot, Turret Bearing	Every 6 Months	7	Chassis Grease
4	Roller Swing Pivot	Every 6 Months	2	Chassis Grease
5	Roller Axle	Every 6 Months	10	Chassis Grease
6	Upper Roller Axle	Every 6 Months	2	Chassis Grease
7	Idler Axle	Every 6 Months	2	Chassis Grease
8	Vessel Pivot	Every 6 Months	1	Chassis Grease
①	Throttle Lever Pivot	Every 6 Months	1	Gear Oil

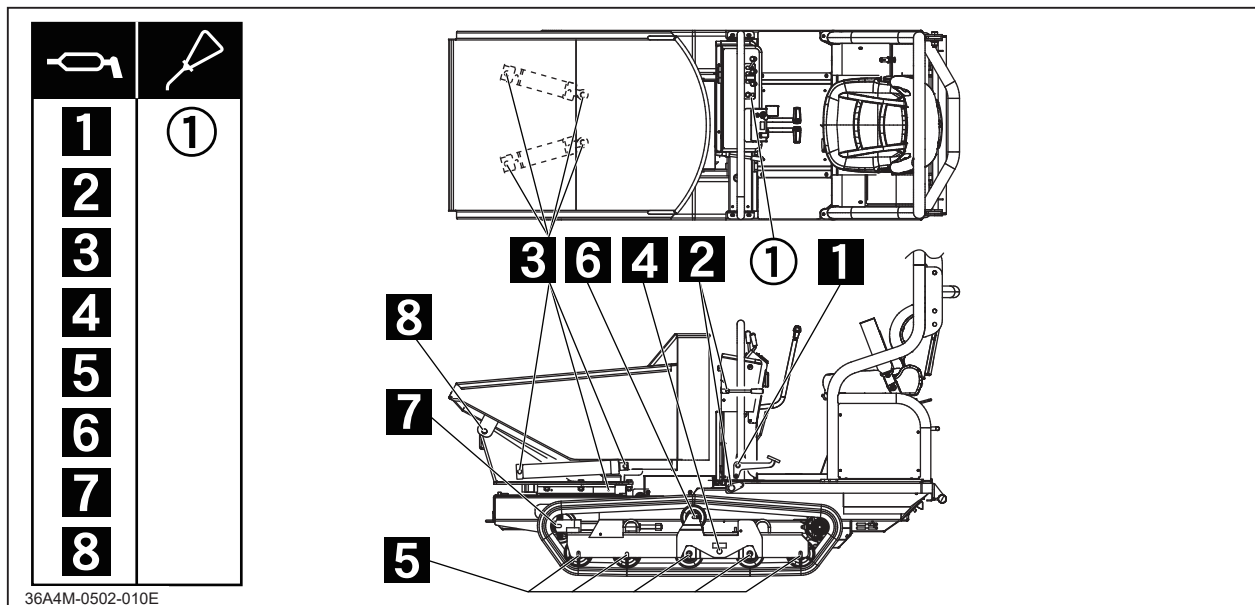

To grease the roller axle,

1. Remove the cap nut.
2. Install the grease nipple (included in the tool bag) onto the axle nut securely.
3. Grease the axle with grease pump.
4. Remove the grease nipple and install the cap nut.

Consumables and Spares

⚠ CAUTION

- Use only CANYCOM genuine parts when replacement or repair is required. CANYCOM assumes no liability whatsoever if any problem occurs as a result of using any part that is not a genuine CANYCOM part.

NOTE

- Rubber products deteriorate over time. Replace them every 2 years.
- You can see our online parts manual at the URL or the QR code below:
<https://www.canycom.jp/eng/maintenance/parts/>
Go to the site and look up your model in the list.
- Consumable parts are listed in a separate page for your convenience.
https://www.canycom.jp/maintenance/recomment/consumables_S100B00.pdf
(This links to a PDF file. You need Adobe Reader or similar software to read it.) This file contains a list of items such as oil filter cartridge, air cleaner element, spark plug, drive belts and mower blades. Open this file to look up your model in the list. For other parts, refer to the parts catalog above.
- In case you cannot see the above parts manual, contact your CANYCOM representative.
- Order replacement parts through your local CANYCOM representative.



Engine

WARNING

- Always stop the engine and remove the key before servicing.
- An engine that has been running is very hot. Allow the engine to cool before servicing, or severe burns may result.
- Keep fire and spark away when servicing the engine or handling fuel.

CAUTION

- Dispose of the drained oil or fluid properly. Check the national and local regulations for discarding engine oil or other fluids.

Engine Oil

CAUTION

- Make certain to fill the engine with correct grade of oil to the specified level. Insufficient amount or wrong grade of oil reduces performance and can cause permanent damage to the engine.

NOTE

- To obtain correct reading, check oil level before starting, or wait about 10 minutes after stopping the engine to allow oil to drain back to the oil pan.
- Always check oil level on a level surface.
- Refer to the Operator's Manual for the Engine when servicing the engine.
- Oil to use and amount: see Page 38.

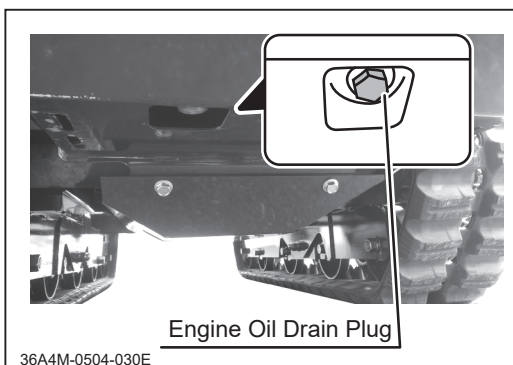
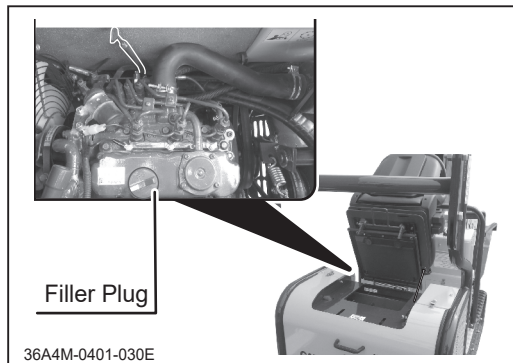
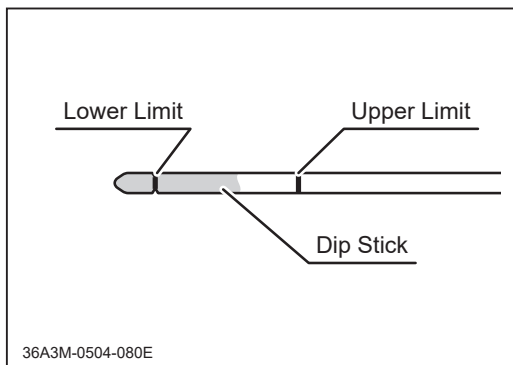
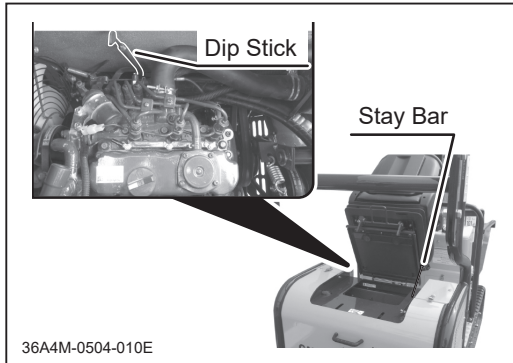

Inspecting

1. Park the machine on a level surface.
2. Unlock the seat lock lever, lift up the seat, and hold it with the seat stay bar.
3. Pull out the dip stick and wipe it clean. Insert the dip stick fully and pull it out again.
4. Visually inspect oil level. If it is below the lower limit, add oil.
5. Visually inspect the condition of oil. If it is too dirty or viscosity is not normal, change oil.
6. Put the dipstick back in place.
7. Undo the seat stay bar and lower the seat gently until it locks.

Filling

1. Unlock the seat lock lever, lift up the seat, and hold it with seat stay bar.
2. Remove the oil filler cap.
3. Fill specified amount of correct oil into the filler.
4. Check oil level. Make sure the oil level is as specified.
5. Replace the oil filler cap.
6. Undo the seat stay bar and lower the seat gently until it locks.

Changing

1. Have an appropriate oil drain pan.
2. Unlock the seat lock lever, lift up the seat, and hold it with seat stay bar.
3. Remove the oil filler cap.
4. Remove the engine oil drain plug to drain oil.
5. Clean drain plug and put it back in place and tighten it securely.

6. Fill specified amount of correct oil into the filler.
7. Check oil level. Make sure the oil level is as specified.
8. Replace the oil filler cap.
9. Undo the seat stay bar and lower the seat gently until it locks.

NOTE

- Refer to the Operator's Manual for the Engine for other engine service items.

Oil Filter Cartridge

⚠ CAUTION

- Use only the genuine CANYCOM oil filter cartridge. Use of non-genuine part can result in damages.

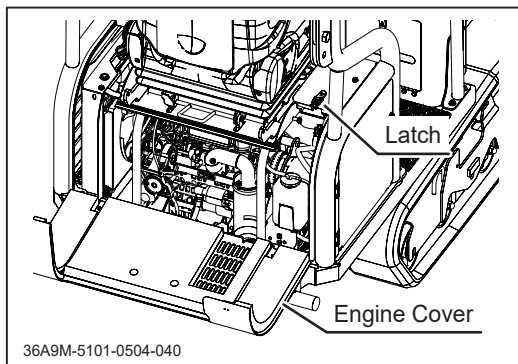

1. Unlatch the latches and open the engine cover.

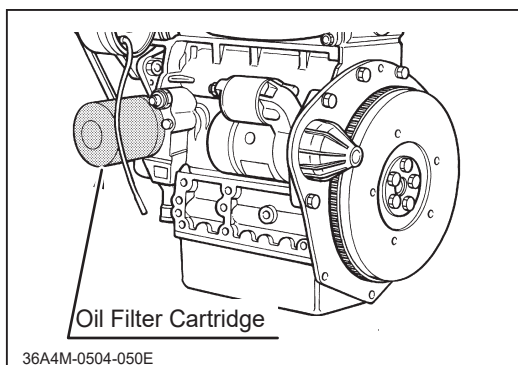

2. Remove the oil filter cartridge with a filter wrench.

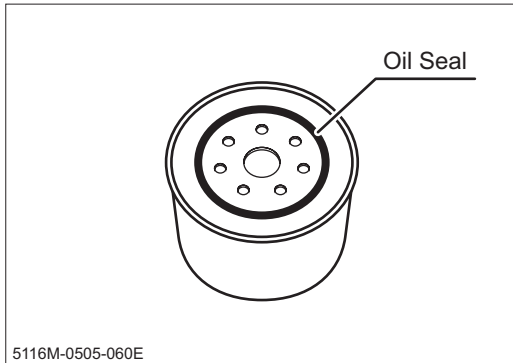

3. Apply a thin coat of clean oil evenly on the oil seal on a new filter cartridge.
4. Install the new cartridge. Tighten it fully by hand. Do not use oil a filter wrench when installing.
5. Check oil level.
6. Start engine to make sure there is no leak on the base of the oil filter cartridge.
7. Close the engine cover and lock the latches.

Air Cleaner

⚠ CAUTION

- Use compressed air to clean the element. Do not tap it to clean. It can deform.

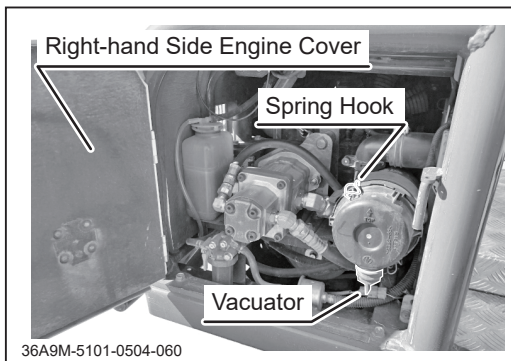

Cleaning Vacuator Valve

1. Open the right-hand side engine cover.
2. Pinch the Vacuator rubber valve to expel dust caught in it. If water comes pout, clean the air cleaner element.
3. Close the right-hand side engine cover.

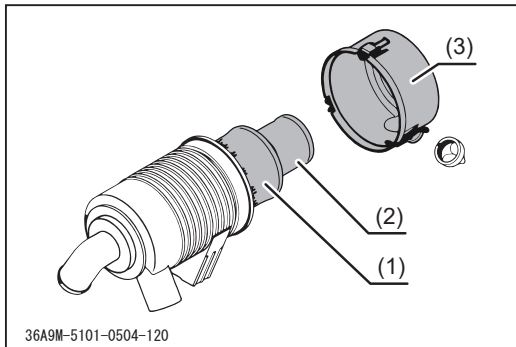

Primary Element – Cleaning

1. Open the right-hand side engine cover.
2. Undo the spring hooks that secure the air cleaner lid.
3. Blow air from inside to clean the primary element. Air pressure must not exceed 205kPa (2.1kgf/cm²). Allow enough space between the element and the nozzle and blow carefully so as not to damage the element.
4. Install the air cleaner lid (3) with its [↑] pointing upwards. Fasten the spring latches.
5. Close the right-hand side engine cover.

Primary Element – Replacing

1. Replace the element once a year or six cleanings, whichever comes sooner.

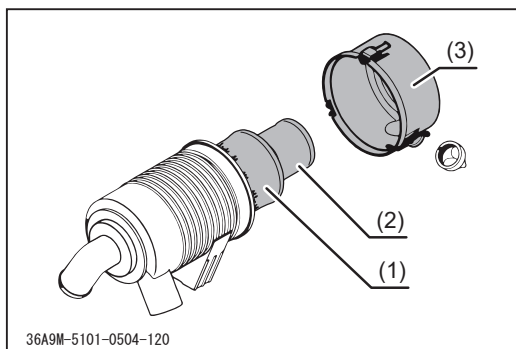

Secondary Element – Replacing

NOTE

- Secondary element is not intended to be cleaned. Replace it when necessary.

1. Replace the secondary element (2) when replacing the primary element (1).
2. Install the air cleaner lid (3) with its [↑] pointing upwards. Fasten the spring latches.

Coolant

⚠ CAUTION

- Do not open the radiator cap when the engine or radiator is hot. Opening cap when they are still hot may release boiling coolant and cause severe burns. Wait for the engine to cool after operation (about 30 minutes) before opening.
- When overheat warning light is lit, coolant may not be sufficient. Check coolant level.

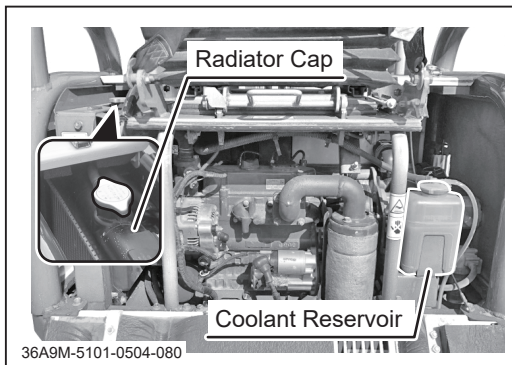

Inspecting/Filling

1. Unlatch the latches and open the engine cover.
2. Visually inspect the coolant level in the coolant reservoir. Make sure it is between the [FULL] and [LOW] lines.
3. If the coolant level is close to, or below the [LOW] line, open the radiator cap and fill.

NOTE

- **Coolant capacity:** About 3.1 L (3.3 US qt) (0.7L in the Reservoir)(0.7 US qt).
 - **Coolant type to use:** Use ethylene glycol Long-Life Coolant (LLC).
 - **Recommended Ratio:** 50% LLC to 50% water in volume [Freezing point -37°C (-34.6°F) Boiling Point 108°C (226.4°F)].
4. Put the radiator cap back and tighten it securely.
 5. Close the engine cover and lock the latches.

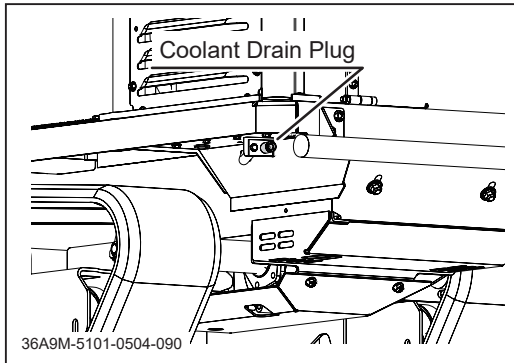

Changing

1. Have an appropriate drain pan big enough to hold all the coolant.
2. Open the coolant drain cock at the bottom of the radiator to drain coolant.
3. Unlatch the latches and open the engine cover.
4. Remove the radiator cap and wash inside the radiator with running water.
5. Close the drain cock.
6. Fill coolant into the radiator and the reservoir tank.
7. Reinstall the radiator cap.
8. Close the engine cover and lock the latches.

Fan Belt

NOTE

- Adjust belt tension properly. Improperly tensioned belts may reduce performance and its service life.

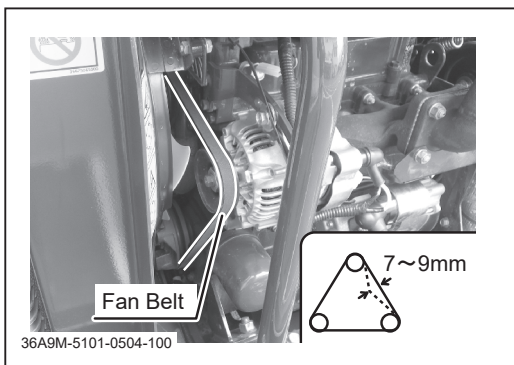

Inspecting/Adjusting

1. Unlatch the latches and open the engine cover.
2. Press the center of fan belt with a finger to check tension.
Deflection shall be between 7mm and 9mm (0.28 in and 0.35 in) with a force of 10kgf(22 lbf).
3. If deflection is not within that range, loosen the alternator mounting bolts and move the alternator to adjust tension.
4. Tighten mounting bolts.
5. Close the engine cover and lock the latches.

Fuel System

⚠ WARNING

- Always stop the engine when servicing the fuel system.
- Fuel is highly flammable. Keep fire and spark away when servicing the fuel system or handling fuel. If fuel is spilt, wipe immediately.

⚠ CAUTION

- Dispose residual fuel in fuel filter or drained fuel or water properly. Check the national and local regulation for discarding such fluids.
- Keep dust and dirt out when servicing the fuel system. Dust in the fuel system damages the fuel pump or injectors.

Bleeding Air in the Fuel System

NOTE

Bleed air when air enters the fuel system

- After changing fuel filter or disconnecting fuel line.
- After running engine until fuel tank is completely dry.

When air is in the fuel system, the engine cannot run.

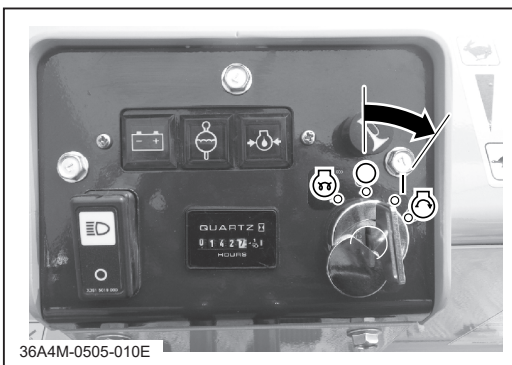

1. Fill fuel into the fuel tank.
2. Turn the main switch to [| (on)] and let the fuel pump run for about 5 seconds to bleed air.

NOTE

- The engine has automatic bleeding system.
3. Turn the main switch off.

Draining Water Separator

NOTE

- Water separator collects water and impurities in the fuel. When the red float in the water separator cup goes up, drain the water separator as described below.

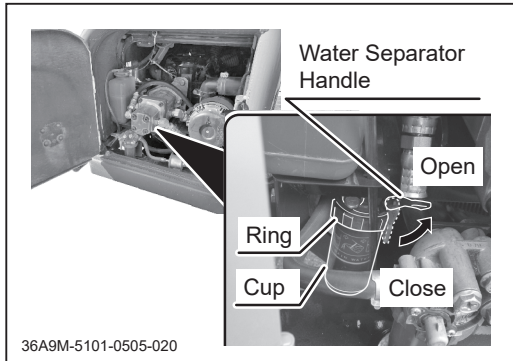

1. Open the right-hand side engine cover.
2. Turn the water separator handle to [CLOSE] position.
3. Unscrew the ring to remove the fuel cup.
4. Wash the cup with clean diesel fuel.
5. Install the fuel cup.
6. Turn the water separator handle to [OPEN] position.
7. Close the right-hand side engine cover.

NOTE

- Refer to the Operator's Manual for the Engine for other engine service items.

Draining Water From Fuel Tank

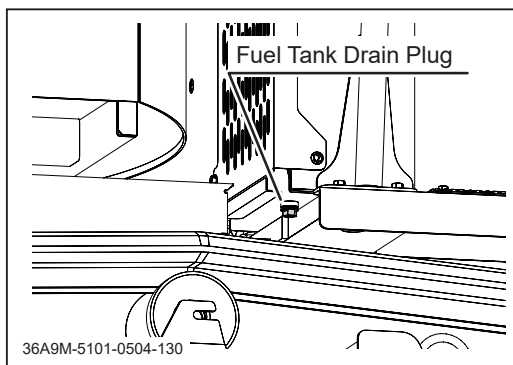

1. Use pump to empty fuel tank.
2. Have an appropriate oil drain pan to catch remaining fuel and water.
3. Remove the fuel tank drain plug to drain remaining fuel with water and sediments in the tank.
4. Install the fuel tank drain plug.
5. Fill fuel in the tank.

Fuel Filter

⚠ CAUTION

- Dust or foreign objects can damage the fuel system. Clean fuel filter and filter cup regularly. When disconnecting the fuel hose, cap the hose and hose fitting with clean caps.

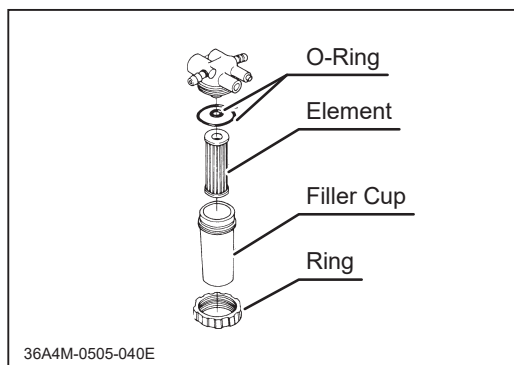

1. Open the right-hand side engine cover.
2. Turn the fuel filter cock to [CLOSE] position.
3. Unscrew the ring to remove the fuel cup.
4. Wash the filter element and cup with clean diesel fuel.
5. Carefully install the fuel bowl so dust or foreign objects do not get inside.
6. Turn the fuel cock to [OPEN] position.
7. Close the right-hand side engine cover.

Hydraulic System

⚠ WARNING

- Always stop the engine when servicing.
- A machine that has been running is very hot. Allow the machine and oil to cool before servicing, or severe burns may result.

⚠ CAUTION

- When hydraulic oil level gets low, air can enter the hydraulic system and impairs its performance. Make certain to fill the hydraulic system with correct grade of oil to the specified level.
- Dispose of the drained oil properly. Check the national and local regulations for discarding engine oil.

Hydraulic Oil

NOTE

- To obtain correct reading, check oil level before starting the engine. Hot oil expands in volume, and correct reading cannot be obtained.
- Always check oil level on a level surface.
- Change the suction filter when changing hydraulic oil.
- Oil to use and amount: see Page 38.

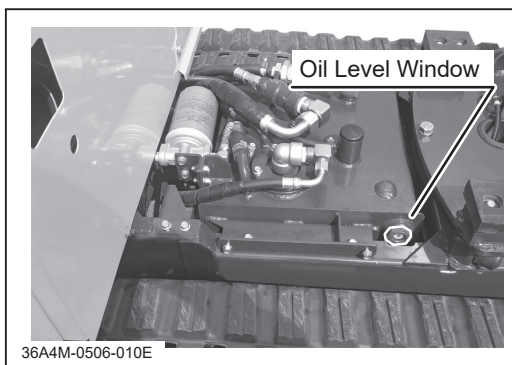

Inspecting/Filling

1. Park the machine on a level ground.
2. Raise the bucket and secure it with the safety prop.

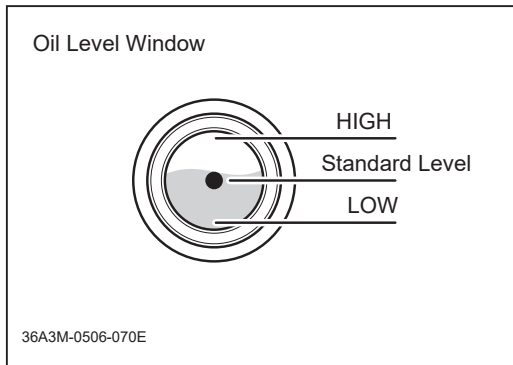

3. Visually inspect the oil level window for oil level and condition.
4. If the level is low, fill oil.
5. If oil is dirty, change oil.

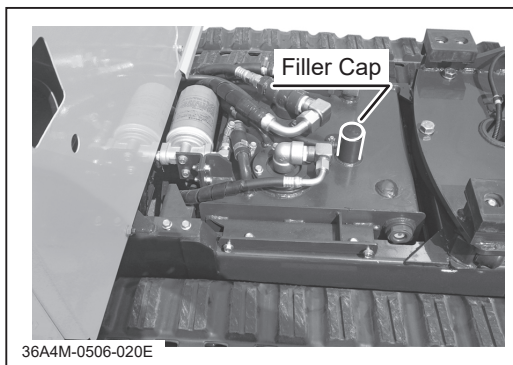

Filling

1. Remove four (4) M8 bolts to remove the oil tank cover.
2. Remove the filler cap.
3. Fill specified grade of oil into the filler.
4. Check oil level.
5. Put the filler cap back in place.
6. Install the pump cover with four (4) M8 bolts.

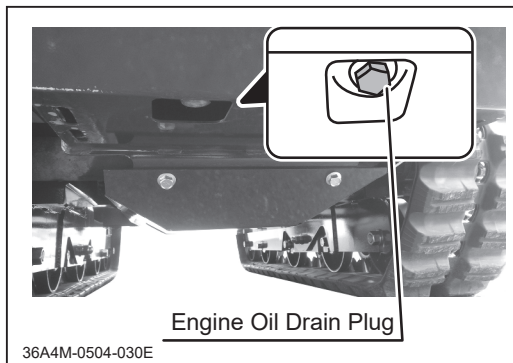

Changing

1. Park the machine on a level ground.
2. Have an appropriate oil drain pan.
3. Remove the hydraulic oil drain plug to drain oil.
4. Install drain plug.
5. Fill oil to the correct level.
6. Start the engine and bleed air from the hydraulic system.
7. Check oil level again to make sure the level is correct.

NOTE

- Oil level may get lower after bleeding air from the hydraulic system.

Suction Filter

NOTE

- Change suction filter when changing hydraulic oil.

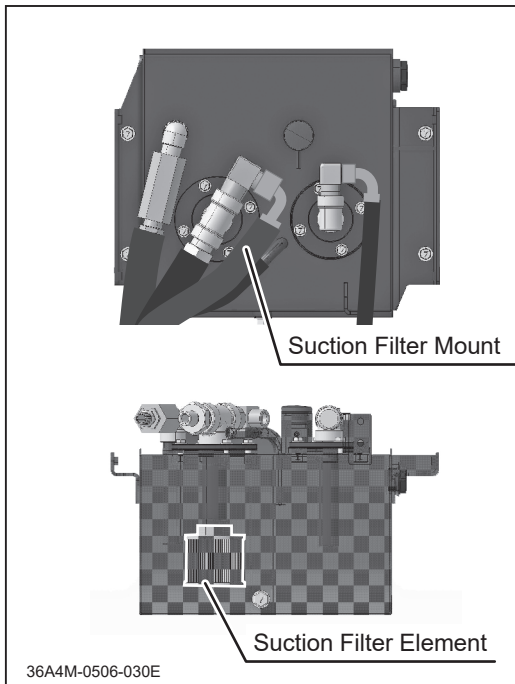

1. Drain oil.
2. Loosen hose bands and remove the hoses.
3. Remove bolts on the flange to remove the suction filter mount.
4. Remove the suction filter element from the filter mount.
5. Install a new suction filter element.
6. Install the suction filter mount.

NOTE

- Take extra care not to damage the O-ring when installing the suction filter mount.

7. Install the hoses and secure them with the hose bands.
8. Fill oil.

NOTE

- Make sure there is no leak in the hose joints and filter mount.

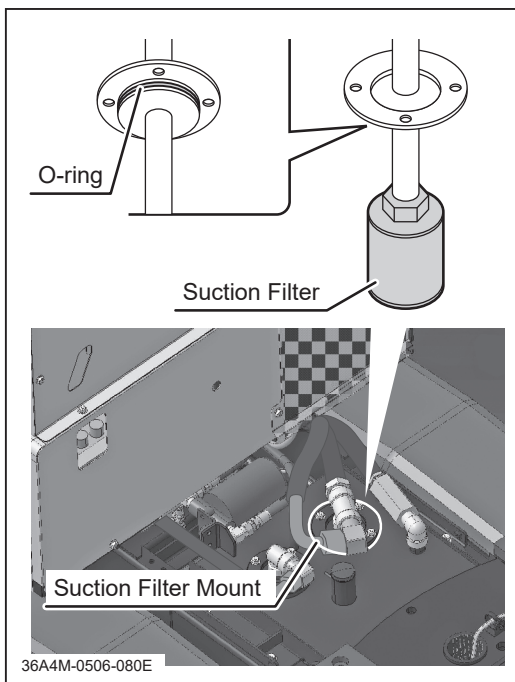

Oil Line Filter Cartridge

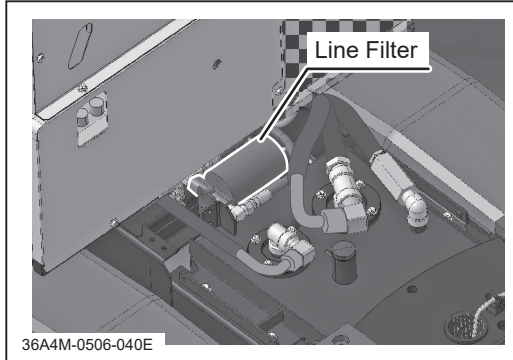

1. Remove four (4) M8 bolts to remove the oil tank cover.
2. Remove the oil line filter cartridge.

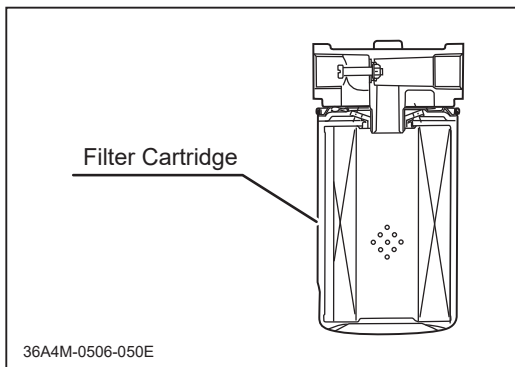

3. Install a new oil line filter cartridge.
4. Check hydraulic oil level. If low, fill.
5. Install the pump cover with four (4) M8 bolts.

Hydraulics Belt

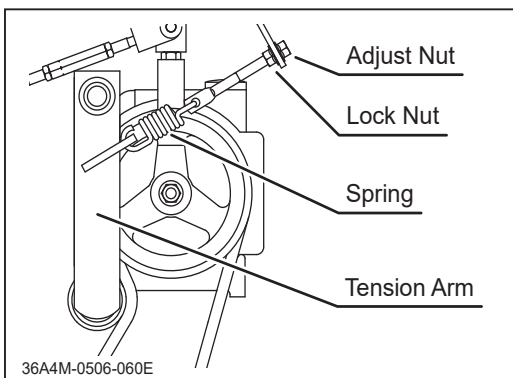

Inspecting

1. Unlatch the latches and open the engine cover.
2. Visually inspect the drive belt. If it is damaged, replace.

NOTE

- Contact your CANYCOM representative when belt needs to be replaced.

3. Close the engine cover and lock it with the latches.

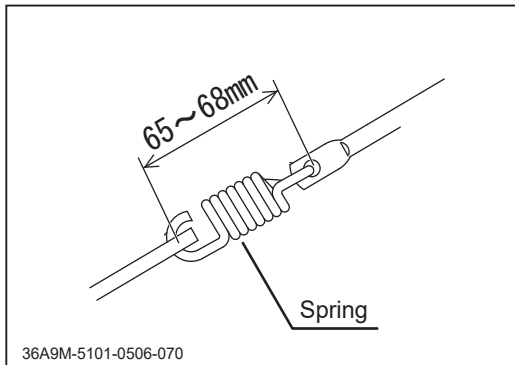

Adjusting

1. Unlatch the latches and open the engine cover.
2. Loosen the lock nuts.
3. Adjust the turnbuckle so that the inside dimension between the spring hooks is between 65 and 68 mm (2.56 and 2.68 in).
4. Tighten the lock nuts.
5. Close the engine cover and lock it with latches.

Drive Train

⚠ WARNING

- Stop the engine when servicing the drive train.
- Allow the machine to cool off before servicing. The machine is very hot after operation and may pose a burn hazard.

Tracks

⚠ WARNING

- Always unload machine before jacking up.
- Jack up the machine securely with a jack capable of supporting the machine's weight when inspecting or adjusting the track. Follow jack manufacturer's instructions to raise one side of the machine until the track is off the ground.
- Once jacked up, support the machine securely with rigid racks.
- Make certain to adjust track tension properly. Improperly tensioned tracks may wear or come off, resulting in property damage, serious injury or death.

⚠ CAUTION

- Track is very heavy. Handle it with care.

NOTE

- During the initial hours of use, track tends to get broken in and stretch more than usual. Inspect often and adjust as necessary.
- Track tension gets loose during its use-life for wear or bedding of the sprocket and track. Inspect and adjust regularly.

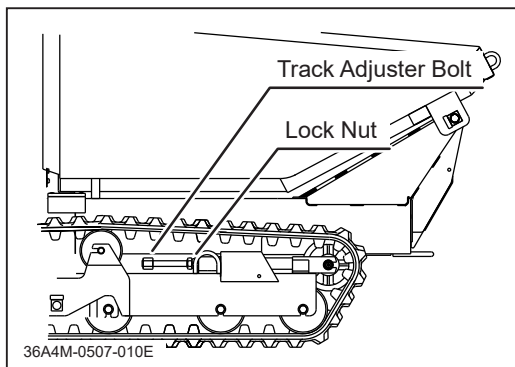

1. Park the machine on a level ground.
2. Jack up the machine so that one side of the tracks is parallel to and off of the ground.
3. Loosen the lock nut on the track adjuster bolt.

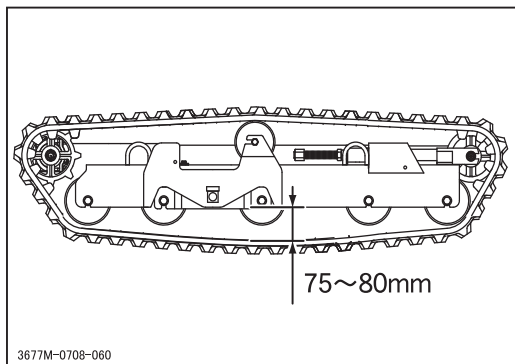

4. Turn the track adjuster bolt to adjust clearance between track and frame to be between 75 and 80 mm(2.95 and 3.15 in).
5. Tighten the lock nut.
6. Lower the machine.

Drive Lever

NOTE

- Steering levers are properly adjusted at the time of shipment. Adjustment is needed only when transmission, steering levers, or their linkage is replaced or dismantled.

Inspecting

1. Start the engine and increase engine speed by moving the throttle lever to [ (fast)] position.
2. Operate the machine on a level surface and release the drive levers; if the track moves forward or backward, corresponding steering lever needs to be adjusted.

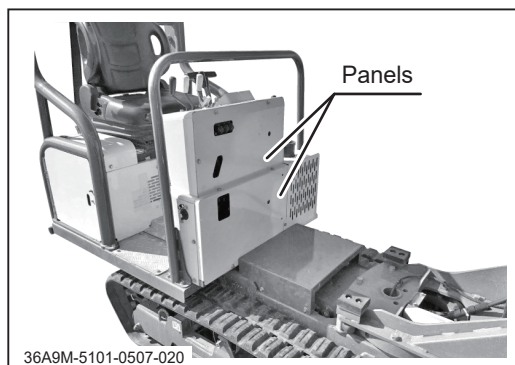

Before Adjusting

1. Raise the bucket and support it with the safety prop.
2. Lock the dump lever with lock plate.
3. Remove the panels on the back of the control panel.

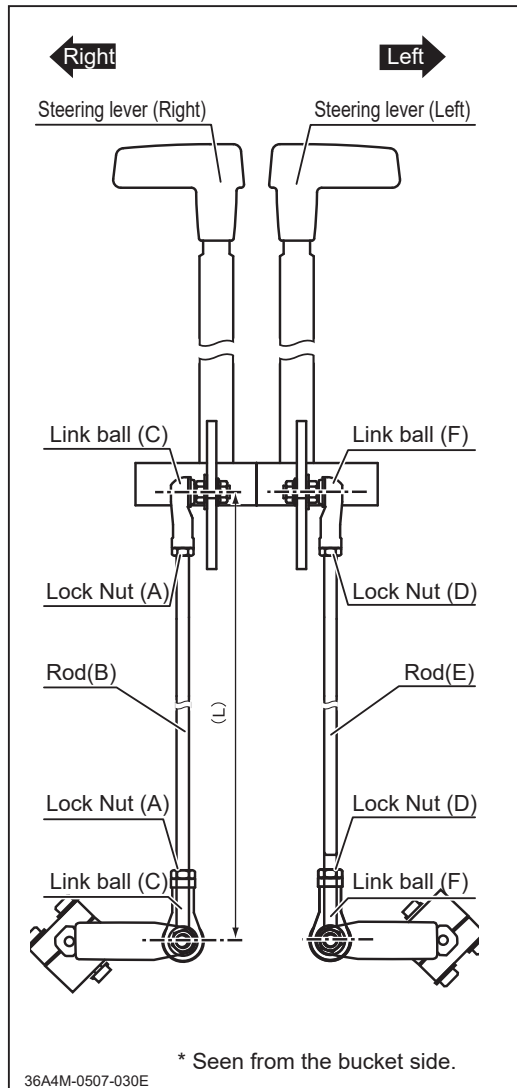

Adjusting - When Right Track Moves

3. Loosen the two lock nuts (A).
4. Rotate the rod (B) until the right track does not move.
 - When the track moves forward, turn the rod so that the distance [L1] between the rod ends (C) becomes shorter.
 - When the track moves backward, turn the rod so that the distance [L1] between the rod ends (C) becomes longer.
5. Tighten the lock nuts (A) securely.

Adjusting - When Left Track Moves

6. Loosen the two lock nuts (D).
7. Rotate the rod (E) until the left track does not move.
 - When the track moves forward, turn the rod so that the distance [L2] between the rod ends (F) becomes shorter.
 - When the track moves backward, turn the rod so that the distance [L2] between the rod ends (F) becomes longer.
8. Tighten the lock nuts (D) securely.
9. Install the plates behind the control panel.

Transmission Oil

⚠ CAUTION

- Dispose of the drained oil properly, according to the national and local regulations.

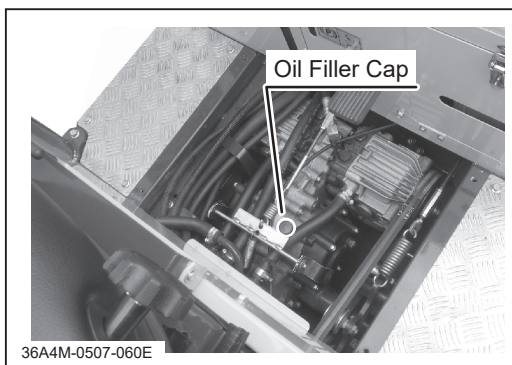
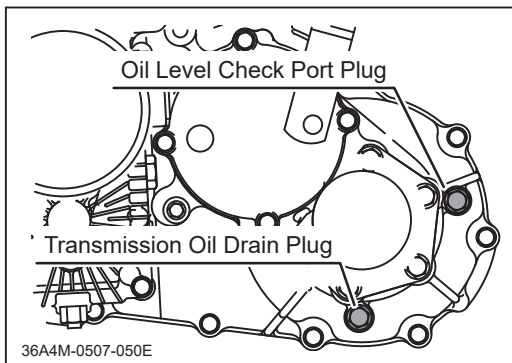
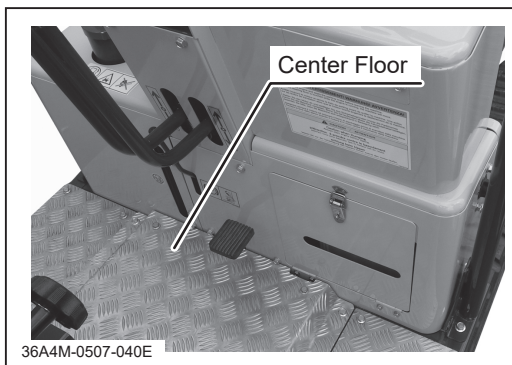

Checking/Filling

1. Park the machine on a level ground and remove the center floor.
2. Remove the oil level check port plug and inspect the oil level to be at the check port. If oil level is low, fill.
3. Visually inspect the condition of oil. If it is dirty or its viscosity is not normal, change oil.
4. Remove the oil filler cap and fill lubricant into the filler until oil comes out of the check port.
5. Reinstall the check port plug and oil filler cap.
6. Reinstall the center floor.

Changing

1. Park the machine on a level ground.
2. Have an appropriate oil drain pan ready.
3. Remove the floor.
4. Remove the transmission oil drain plug to drain oil.
5. Clean the drain plug and reinstall it. Tighten it securely.
6. Remove the oil filler cap and oil level check port plug.
7. Fill oil slowly until oil flow out of check port.

8. Install check port plug and filler cap.
9. Reinstall the center floor.

Drive Belt

⚠ CAUTION

- Adjust belt tension properly. Improperly tensioned belts may reduce performance and its service life.

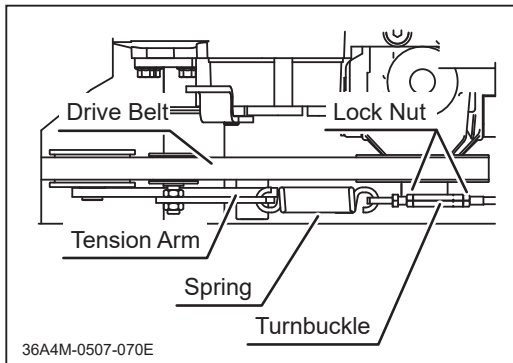

Inspecting

1. Push the clutch lever to [ (engaged)] position.
2. Remove the safety cover.
3. Visually inspect the drive belt. If it is damaged, replace.
4. Reinstall the safety cover.

NOTE

- Contact your CANYCOM representative when belt needs to be replaced.

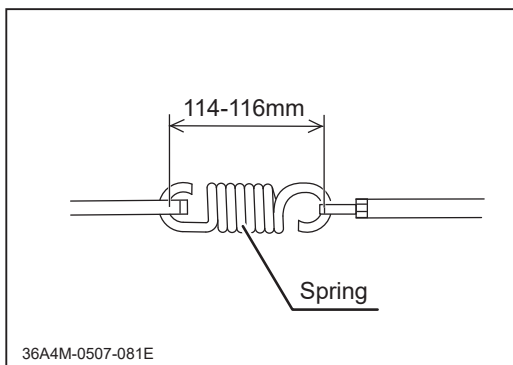

Adjusting

1. Remove safety cover.
2. Loosen the lock nut.
3. Adjust the turnbuckle so that the inside dimension between the spring hooks is between 114 and 116 mm (4.49 and 4.57 in).
4. Tighten the lock nuts.
5. Install the safety cover.

Parking Brake

⚠ WARNING

- Always keep brake adjusted for maximum performance. Improperly adjusted brakes may result in property damage, serious injury, or death.

⚠ CAUTION

- Use the parking brake with the drive levers in the neutral position.

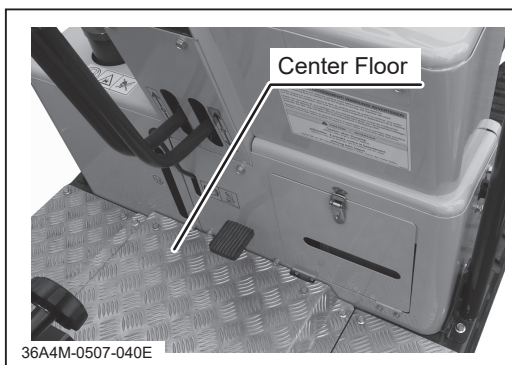

1. Remove the center floor.
2. Depress the parking brake pedal and lock it securely with the lock lever.

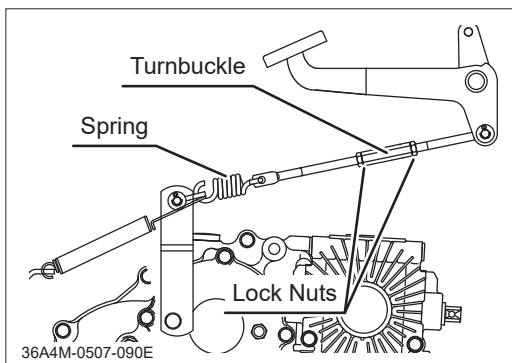

3. Loosen the lock nuts on the brake linkage.

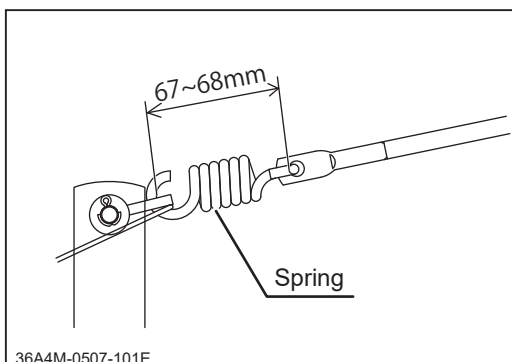

4. Adjust the turnbuckle so that the distance between the spring hooks is between 67 and 68mm (2.64 and 2.68 in).
5. Tighten the lock nuts securely.
6. Install the center floor.

Electrical System

WARNING

- Always stop the engine and turn the main switch to [ (off)] position, and disconnect the negative (-) terminal of battery when servicing the electrical system.
- Do not work on the electrical system with wet hands. Electric shock can result.

Battery

WARNING

- Never use or charge the battery when the fluid level is below the lower limit. Charging battery with insufficient fluid may shorten battery life or cause an explosion.
- Battery fluid (diluted sulfuric acid) is corrosive and causes severe burns. Be extremely cautious when handling battery fluid. If battery fluid is spilt on clothes, immediately rinse with plenty of water. If spilt on skin or in an eye, immediately rinse with plenty of water and promptly consult a physician.
- Explosion hazard. Keep open flame or spark away from the battery. Hydrogen gas generated during use or charging is extremely explosive.
- Use wet cloth to clean the battery. Dry cloth may generate static electricity, which can cause explosion.
- Do not touch the battery terminals. Electric shock may occur.
- Always disconnect the negative (-) terminal first, and connect the positive (+) terminal first. Disconnecting or connecting in the opposite order may cause a short circuit.
- When installing the battery, make certain to connect the positive (+) and negative (-) terminals to their respective original positions. Avoid contact between terminals and other surrounding parts.

⚠ CAUTION

- Never fill battery fluid beyond the [UPPER LEVEL] line. Battery fluid can spill and cause damage to the machine or personal injury.
- Always remove the battery from the machine before charging. Failure to do so can cause damage to the electrical components and wiring.
- Follow the battery charger user's manual when charging.

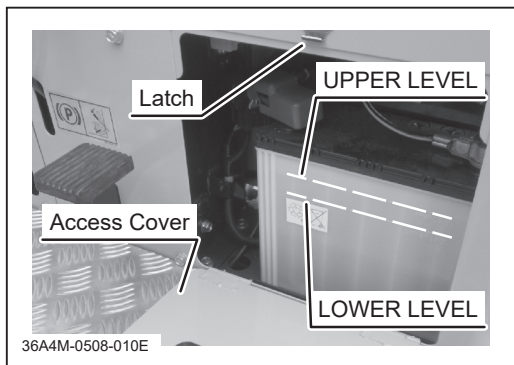

Inspecting

1. Park the machine on a level ground.
2. Unlatch the latch and open the access cover below the control panel.
3. Visually inspect that the battery fluid level is between the [UPPER LEVEL] and [LOWER LEVEL] lines.
4. If the fluid level is below the "Lower Level," fill.
5. Close the access cover and lock the latch.

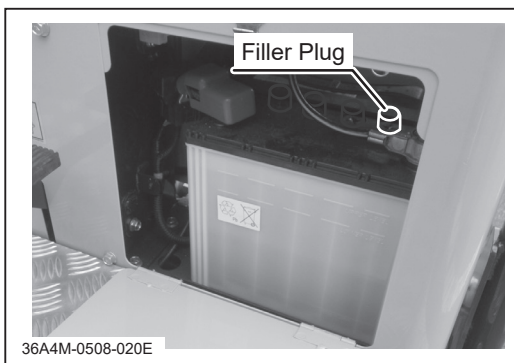

Filling

1. Unlatch the latch and open the access cover.
2. Remove the battery filler plugs.
3. Fill distilled water up to "Upper Level" line.
4. Reinstall the filler plugs.
5. Close the access cover and lock the latch.

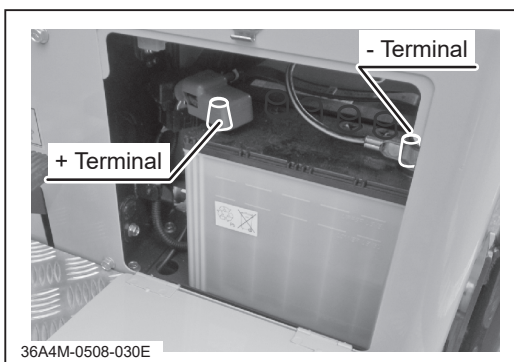

Charging

1. Park the machine on a level ground.
2. Unlatch the latches and open the engine cover.
3. Remove the cable from the negative (-) terminal.
4. Remove the cable from the positive (+) terminal.

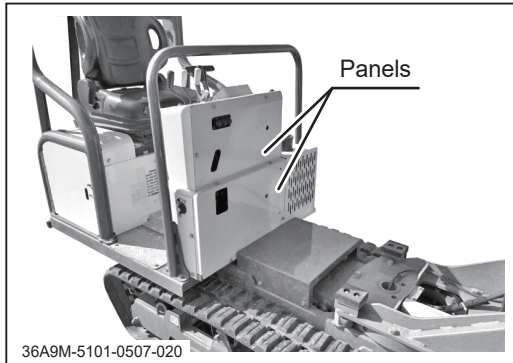

5. Undo four (4) M8 bolts and one M8 nut to remove the lower part of the front panels.
6. Remove the battery from the machine.

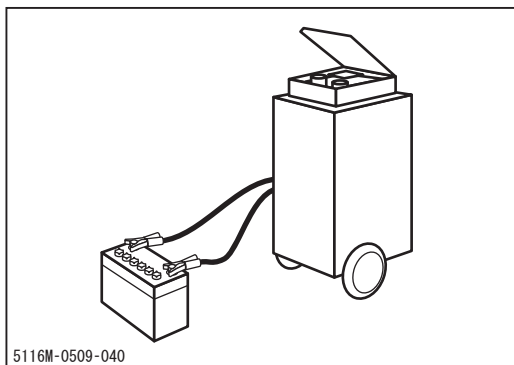

7. Follow the instructions in **the battery charger user's manual** to charge the battery.
8. When the battery is fully charged, relace the filler plugs and reinstall the battery.
9. Reinstall the lower part of the front panels.
10. Attach the electrical cables in the reverse order of removal.
11. Close the engine cover and lock the latches.

NOTE

- **Rapid charging is only an emergency measure. This method uses a large amount of current to compensate the lost charge in a short time. However, the battery needs to be fully charged in the ordinary method for a longer service life.**

Fuses

⚠ CAUTION

- **If a fuse blows, investigate the cause and repair it before replacing the fuse.**
- **Always replace a fuse with the one of the correct rating.**

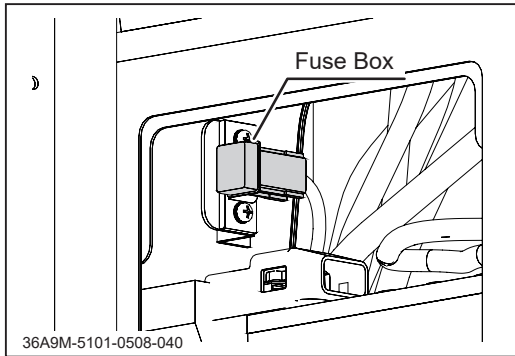

Fuses

1. Unlatch the latch and open the access cover under the control panel.
2. Open the fuse box lid.
3. Locate the blown fuse and replace it with a new one of the correct rating.
4. Replace the lid.
5. Close the access cover and lock the latch.

NOTE

- **Lights and Horn: 10A**
- **Fuel Pump/Indicators/Hour Meter: 10A**

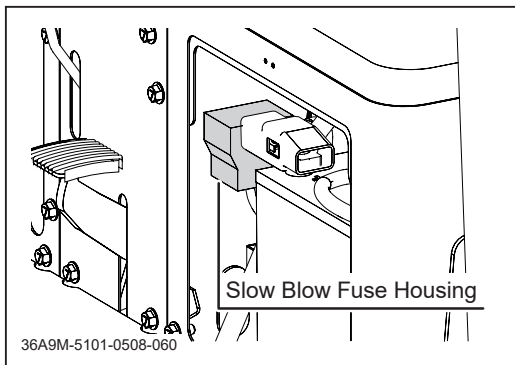
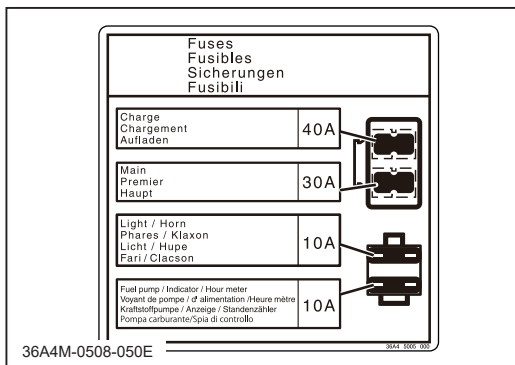

Slow Blow Fuses

1. Unlatch the latch and open the access cover under the control panel.
2. Open the slow blow fuse box.
3. Locate the blown fuse and replace it with a new one of the correct rating.
4. Close the slow blow fuse box.
5. Close the access cover and lock the latch.

NOTE

- **Charge: 40A**
- **Main: 30A**

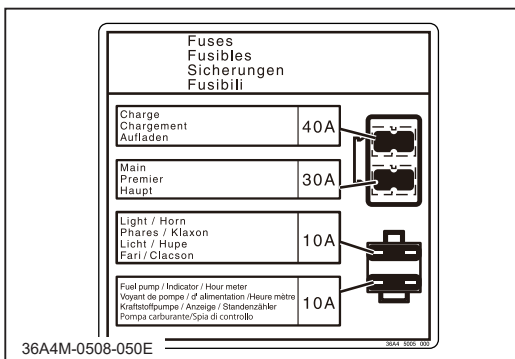

Relays

⚠ CAUTION

- If a fuse blows, investigate the cause and repair it before replacing the fuse.
- Always replace a fuse with the one of the correct rating.

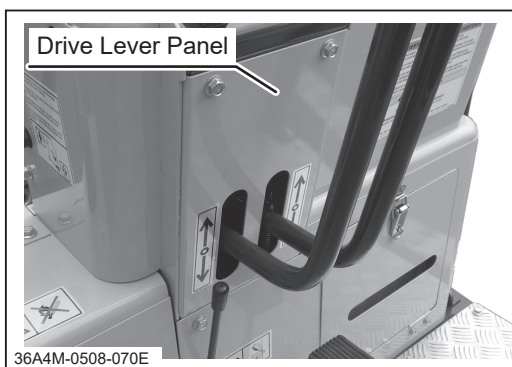

1. Undo four (4) M8 bolts to remove the drive lever panel.

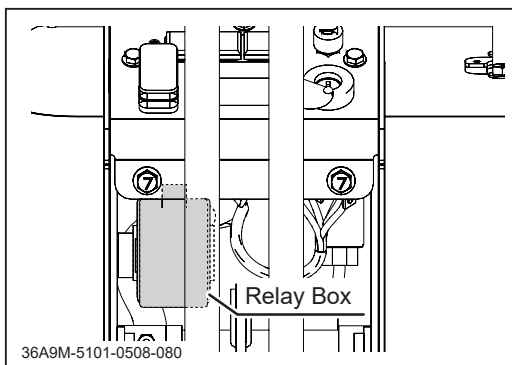

2. Open the relay box and inspect the relays.
3. If a relay is found broken, replace it.
4. Reinstall the drive lever panel.

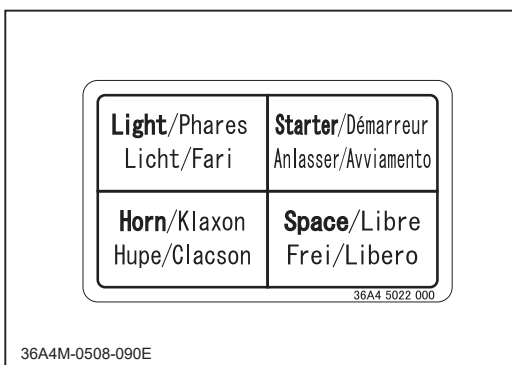

36A4M-0508-090E

After Use Care

⚠ CAUTION

- Do not wash the engine, control panel, electrical parts, or tank caps with air breather with running water; water may enter inside and cause rust or damage.
- Clean the machine after use; leaving dirt or foreign objects may cause damage.
- Do not attempt to move the machine when it becomes inoperable due to freezing.
- Dispose of the residual air spent fuel, oil, coolant, or other fluids, replaced filters, cartridges, damaged parts, etc. properly. There may be regulations for their disposal, and it can be unlawful to dispose them in a way other than prescribed by these regulations. Check the national and local regulations for discarding such materials.

After Normal Use

1. Clean the machine; wash off dirt, mud, and other foreign matter after use.
2. If the machine is to be left outside, cover the machine with protective, water-proof covering after the machine is cooled off.

After Cold Weather Use

1. Clean the machine; wash off dirt, mud, and other foreign matter after use.
2. Park the machine on a paved or firm, dry surface or on a layer of lumber.
3. If the machine is to be left outside, cover the machine with protective, water-proof covering after it is cooled off.

Washing

⚠ WARNING

- High-pressure washer can be dangerous. Never point it to a person. Make sure no one is behind the machine when washing the machine with a high-pressure washer. Also, it can damage the machine. Follow the instruction manual of the high-pressure washer as well as the description below and familiarize with its use.

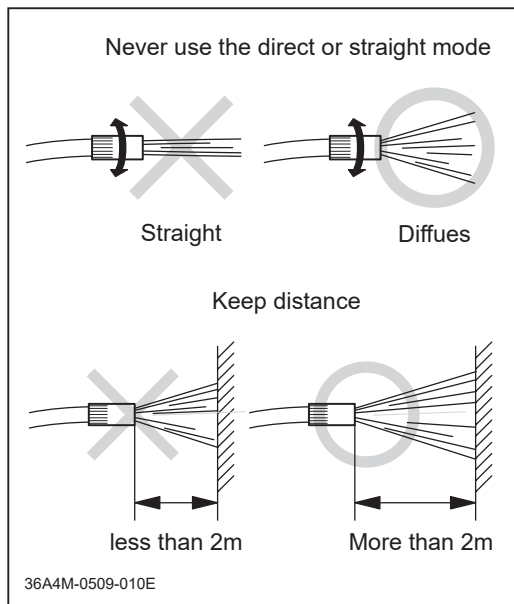

1. Set the washer nozzle (of a hose or a high-pressure washer) to diffuse mode. Never use direct or straight mode.
2. When washing the machine with a running water from a hose or with a high-pressure washer, keep enough distance from the machine (2 meters or more with running water. With a high-pressure washer, refer to its instruction manual).

NOTE

- Water under high pressure can damage the wiring and insulation of the electrical components, which can result in damage, electrical shock, or fire.
- Water under high pressure can damage the hydraulic plumbing, which in turn can cause the hydraulic oil under very high pressure to escape and cause damage or severe injury.
- Water under high pressure can peel off sticker labels, paint and plating, or damage rubber, plastic, or glass parts.
- Water under high pressure can enter inside the engine, transmission, electrical parts, tanks, cabin, etc. to cause damages.



Storage

⚠ WARNING

- Fire hazard; do not store the machine where there is a possibility of ignition.

⚠ CAUTION

- Do not wash the engine or control panel with running water; water may enter inside and cause rust or damage.
- Clean the machine before storage; leaving dirt or foreign objects may cause rust or damage.
- Do not store the machine in a humid, dusty, or hot place.

1. Follow the instructions in **Stopping** (page 26) to park the machine.
2. Move the throttle lever to [ (slow)] position. Do not apply parking brake.
3. Move the clutch lever to [ (disengaged)] position.
4. Clean dirt off of the machine.
5. Follow the **Maintenance Schedule** (Page 32) to perform scheduled services.
6. Wipe clean the steel parts with oiled cloth. Grease the greasing and oiling points.
7. Change engine oil (Page 41).
8. Completely drain engine coolant.
9. Clean the air cleaner element (page 44).
10. Completely drain the fuel tank.
11. Turn the battery kill switch to [ (off)] position. Service battery (page 62).

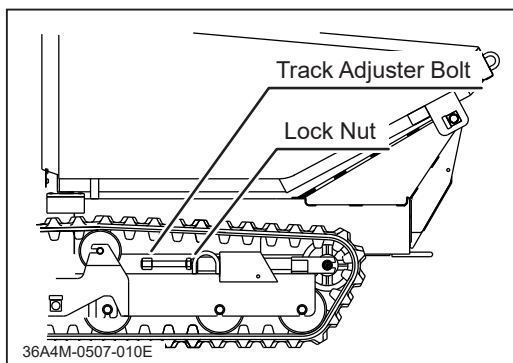

12. Loosen the tracks.
 - a) Loosen the lock nut of the track tensioner.
 - b) Loosen the tensioner bolt.
 - c) Wipe clean the track with oiled cloth.
 - d) Oil or grease the bearings.
 - e) Place wood boards or similar material under the tracks.
 - f) Remove the key from the main switch.
13. Cover the machine with protective, water-proof covering after the machine is cooled off.

NOTE

- **Battery discharges even when it is not in use. A battery may hold charge for a few months, but it is a good practice to charge battery before it goes flat; it will extend the battery life.**
- **Refer to the Operation Manual for the engine, for detailed instructions on preparing the engine for storage.**
- **Before starting up the machine after storage, make sure to fill engine coolant and fill fuel and bleed air from the fuel system. After starting, check for leaks and drive slowly to make sure everything is in order.**

Troubleshooting

- If any malfunction or abnormal condition is found, immediately stop using the machine and take an appropriate measure according to the Troubleshooting chart below. If the malfunction or abnormal condition is not listed in the chart, or the suggested measure does not solve the problem, consult with your CANYCOM representative.
- Some corrective measures listed below require special knowledge and/or equipment. Please contact your CANYCOM representative in such a case.

Area	Malfunction	Possible Cause	Corrective Measure	Ref.
Engine	Engine does not start, or is difficult to start	Parking brake pedal is not depressed. (Safety mechanism is at work.)	→Depress parking brake pedal.	
		Battery cutoff switch is off.	→Turn battery cutoff switch on.	
		Battery cable is disconnected.	→Connect battery cable.	
		Battery is discharged.	→Add battery fluid. →Charge battery. →Replace battery.	Page 62
		Blown fuse.	→Replace fuse.	
		Bad connection or breakage in the wiring.	→Please contact your CANYCOM representative.	
		Starter switch, relay or motor is defective.	→Please contact your CANYCOM representative.	
		Out of fuel.	→Fill fuel.	Page 16
		Air in fuel system.	→Bleed air.	Page 48
		Excessive fuel in the engine.	→Wait a while and try starting again.	
		Water in fuel.	→Drain water.	Page 49
		Foreign objects in fuel system.	→Clean fuel cock/ water separator. →Change fuel filter.	

Area	Malfunction	Possible Cause	Corrective Measure	Ref.
Engine	Engine does not start, or is difficult to start	Insufficient or wrong oil.	→Fill or change oil.	Page 41
		Other (other than the above).	→Please contact your CANYCOM representative.	
	Engine stalls	Out of fuel.	→Fill fuel.	Page 16
		Air in fuel system.	→Bleed air.	Page 48
		Cold engine.	→Warm up engine.	
		Other (other than the above).	→Please contact your CANYCOM representative.	
	Engine stops abruptly	Out of fuel.	→Fill fuel.	
		Piston seizure due to insufficient or bad oil.	→Please contact your CANYCOM representative.	
		Other (other than the above).	→Please contact your CANYCOM representative.	
	Engine does not stop	Electrical malfunction	→Close fuel cock to stop engine. Then, contact your CANYCOM representative for repair.	
		Other (other than the above).		
	Idling is not stable	Insufficient intake air (clogged air cleaner).	→Clean or replace air cleaner.	Page 44
		Other (other than the above).	→Please contact your CANYCOM representative.	
	Poor power or acceleration	Bad fuel	→Change fuel.	
		Wrong oil (inappropriate viscosity)	→Change to suitable oil.	
		Accelerator (throttle) is not properly adjusted.	→Please contact your CANYCOM representative.	
Insufficient intake air (clogged air cleaner).		→Clean or replace air cleaner.	Page 44	

Area	Malfunction	Possible Cause	Corrective Measure	Ref.
Engine	Poor power or acceleration	Excessive load	→Reduce load.	
		Other (other than the above).	→Please contact your CANYCOM representative.	
	Irregular noise or vibration from or around the engine	Loose engine mount.	→Tighten.	
		Other (other than the above).	→Please contact your CANYCOM representative.	
	Excessive oil consumption	Oil leak.	→Locate leak and repair.	
		Worn piston ring or cylinder.	→Please contact your CANYCOM representative.	
		Other (other than the above).	→Please contact your CANYCOM representative.	
	Engine overheats	Insufficient amount of engine oil.	→Fill oil.	Page 41
		Insufficient amount of coolant.	→Fill coolant.	Page 46
		Leak in cooling system.	→Locate leak and repair. Please contact your CANYCOM representative.	
		Radiator is clogged or blocked.	→Clean.	
		Other (other than the above).	→Please contact your CANYCOM representative.	
	Excessive fuel consumption	Leak in the fuel system.	→Please contact your CANYCOM representative for a repair.	
		Clogged air cleaner.	→Clean or replace air cleaner.	Page 44
		Other (other than the above).	→Please contact your CANYCOM representative.	

Area	Malfunction	Possible Cause	Corrective Measure	Ref.
Engine	Black smoke comes out of exhaust	Poor compression.	→Please contact your CANYCOM representative.	
		Bad fuel.	→Change fuel.	
		Clogged air cleaner.	→Clean or replace air cleaner.	Page 44
		Other (other than the above).	→Please contact your CANYCOM representative.	
	White or blue smoke comes out of exhaust	Engine oil level is too high.	→Adjust the oil level.	
		Wrong oil (improper viscosity)	→Change to suitable oil.	Page 41
		Worn piston ring or cylinder.	→Please contact your CANYCOM representative.	
		Other (other than the above).	→Please contact your CANYCOM representative.	
	Accelerator lever does not move smoothly	Deformed or rusty linkage or wire.	→Please contact your CANYCOM representative.	
		Other (other than the above).	→Please contact your CANYCOM representative.	
Drive Train	Machine does not move (forward, backward, turning) when the drive lever is in the corresponding position.	Parking brake is applied	→Release parking brake.	Page 19
		Excessive load	→Reduce load.	
		Drive V-belt is loose, worn, or damaged.	→Adjust or replace. For replacement, please contact your CANYCOM representative.	Page 60
		Hydraulic V-belt is loose, worn, or damaged so there is not enough charge pressure.	→Adjust or replace. For replacement, please contact your CANYCOM representative.	

Area	Malfunction	Possible Cause	Corrective Measure	Ref.
Drive Train	Machine does not move (forward, backward, turning) when the drive lever is in the corresponding position.	Insufficient or deteriorated HST fluid.	→Add or change fluid.	Page 51
		Clogged oil cooler.	→Clean.	
		Foreign objects or contamination in hydraulic system.	→Remove foreign objects or contamination.	
		Clogged hydraulic filter.	→Replace.	Page 53, 54
		Leak in hydraulic system.	→Locate leak and repair.	
		Other malfunction in the hydraulic drive system.	→Refer to the "Hydraulics" section	
		Other (other than the above).	→Please contact your CANYCOM representative.	
Brake	Parking brake does not work well.	Adjust nut is loose.	→Adjust.	Page 61
		Brake lining is worn.	→Please contact your CANYCOM representative to adjust or replace.	
		Water in brake drum.	→Apply brake a few times to dry.	
		Excessive load.	→Reduce load.	
		Other (other than the above).	→Please contact your CANYCOM representative.	
Under-carriage	Track does not move smoothly.	Not properly adjusted.	→Adjust.	Page 55
		Other (other than the above).	→Please contact your CANYCOM representative.	
	Intermittent noise is heard.	Track is loose.	→Adjust.	Page 55
		Track is derailed.	→Put it back and adjust its tension	
		Mount bolt on track roller, upper roller, sprocket, or idler is loose.	→Tighten.	

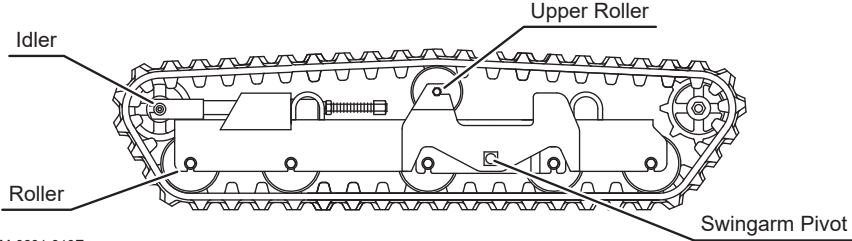
Area	Malfunction	Possible Cause	Corrective Measure	Ref.	
Under-carriage	Intermittent noise is heard.	Track roller bearing is damaged.	→Please contact your CANYCOM representative to replace..		
		Other (other than the above).	→Please contact your CANYCOM representative.		
	Overheating is found in the undercarriage.	Roller, upper roller, idler or sprocket is damaged.	→Please contact your CANYCOM representative to repair or replace.		
		Other (other than the above).	→Please contact your CANYCOM representative.		
	 <p>36A4M-0601-010E</p>				
	Hydraulic System	Hydraulic components (hydraulic motor, cylinder) does not work properly.	Hydraulic V-belt is loose, worn, or damaged so there is not enough charge pressure.	→Adjust or replace. For replacement, please contact your CANYCOM representative.	
Insufficient or deteriorated hydraulic oil.			→Fill or change oil.	Page 51	
Hydraulic oil is contaminated			→Change oil.	Page 51	
Control valve is jammed.			→Clean and repair.		
Oil filter is clogged.			→Change filter.	Page 53, 54	
Oil leaks			→Repair leak.		
Insufficient discharge from hydraulic pump.			→Please contact your CANYCOM representative.		
Other (other than the above).			→Please contact your CANYCOM representative.		

Area	Malfunction	Possible Cause	Corrective Measure	Ref.
Safety Devices	Light does not turn on.	Damaged wiring.	→Repair.	
		Blown fuse.	→Replace.	Page 64
		Other (other than the above).	→Please contact your CANYCOM representative.	
	warning stays on after the engine starts.	Low oil level.	→Fill.	Page 41
		Other (other than the above).	→Please contact your CANYCOM representative.	
	Overheat warning stays on after the engine starts.	Engine is overheating.	→Refer to the Operator's Manual for the engine.	
		Other (other than the above).	→Please contact your CANYCOM representative.	
	Charge warning stays on after the engine starts.	Blown fuse.	→Replace.	Page 64
		Other (other than the above).	→Please contact your CANYCOM representative.	
	Horn does not work.	Loose terminal or broken wire.	→Connect or repair.	
		Blown fuse.	→Replace.	Page 64
		Other (other than the above).	→Please contact your CANYCOM representative.	

Hauling

Loading and Unloading

WARNING

- Park the transporter (truck) on a level ground and apply parking brake. Always use chocks to secure wheels.
- Do not allow bystandars to come close to the machine or the transporter when loading or unloading the machine.
- Use only the loading ramps with suffient strength(to withstand the combined weight of the machine and the operator), width (more than 1.2 times the width of the track), and length (more than 4 times the height of the bed of the transporter), and have anti-slip ramp surfaces.
- Secure the hooks of the loading ramps firmly and flush with the bed of the transporter.
- Move slowly foreward when loading onto, and move slowly backward when unloading off of the transporter. Pay special care when going over the joint between the bed and the ramps; the machine may tip.
- Do not turn on the loading ramps. The machine may fall.
- Tie down the machine securely. Make sure the machine does not move around on the bed of the transporter.

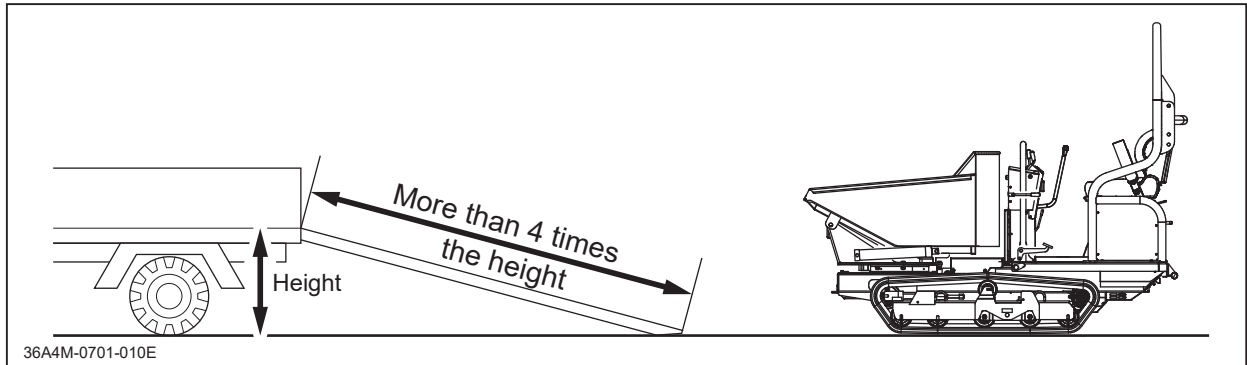

1. Park the transporter and apply parking brake. Secure the wheels with chocks.
2. Place the loading ramps. Secure the hooks of the ramps firmly and flush with the bed of the transporter.
3. Drive the machine slowly forward onto the bed of the truck.
4. Park the machine according to the instructions in **"Stopping"** (Page 26).
5. Tie the machine down securely onto the bed of the transporter with ropes, wires or tie-down belts.

Hoisting

⚠ WARNING

- Hoisting requires qualifications. Check with your local authority for necessary qualifications and licenses for hoisting.
- Use hoisting slings and shackles of sufficient strength. Always use the slings of the same length when more than one is used.
- Beware of the shift in the center of gravity and balance of the machine when hoisting.
- Always unload the machine before hoisting.

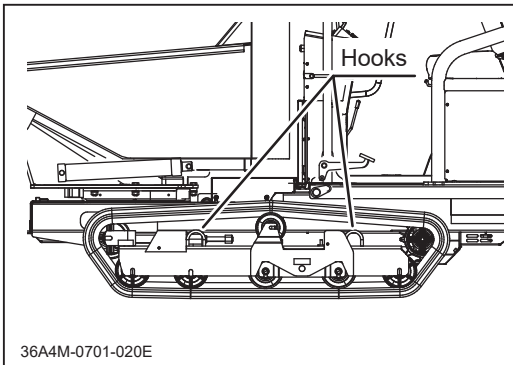

1. Hitch the wire ropes or slings to the lifting hooks (4 places) attached to the track frame and adjust the wire rope length so that the machine will be horizontal.
2. Lift the machine.

NOTE

- Adjust the length of slings so as not to scratch the body.

Folding ROPS (for transportation and storage)

⚠ DANGER

- Do not ride the machine with the ROPS in folded position. The operator can be killed in the event of a rollover accident.
- Do not loosen the bolts or nuts other than the ones specified in the procedure.
- Tighten the bolts and nuts to the specified torque.

⚠ CAUTION

- Perform this procedure on a level surface.
- Loose ROPS can fall. Hold it securely when loosening or removing the bolts and nuts.

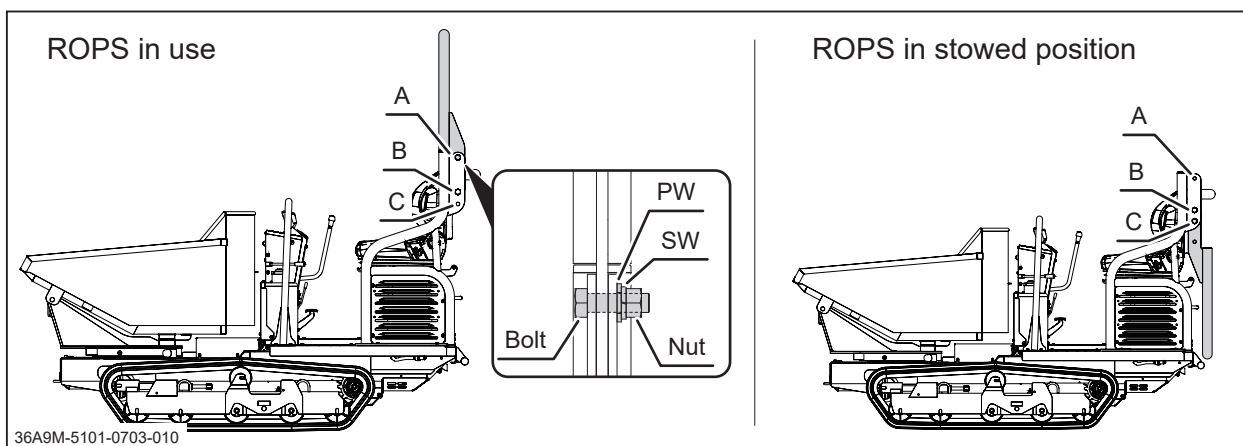

When Folding

1. Undo and remove the nut, plain and spring washers from the Bolt. Then hold the upper portion of the ROPS securely and remove the bolt. (2 places.)
2. Fold the upper portion of the ROPS to the stowed position.
3. Insert the removed bolt to C, insert the plain and spring washers and fasten the nut. (2 places.)

When Raising to the Use Position

Raising is in the reverse order of folding.

NOTE

- Tightening Torque of A: 637N·m (65kgf·m)

NOISE LEVEL

Model	Engine		LpA	LwA
Type	Type	Speed rpm		
S100B	Kubota D902	2800 rpm	89 dB (A)	101 dB (A)

NOISE LEVEL evaluated based on factory standard.

VIBRATION

Model	Engine Speed	Vibration	
		Drive lever	Seat
S100B	2800 rpm	2.2 m/s ² (Uncertainty K=0.5m/s ²)	0.69 m/s ² (Uncertainty K=0.2m/s ²)

VIBRATION evaluated based on factory standard.

CHIKUSUI CANYCOM, INC.

<https://www.canycom.jp/eng/>

CHIKUSUI CANYCOM, INC.
90-1 Fukumasu, Yoshii-machi,
Ukiha-shi, Fukuoka, Japan 839-1396

Sales Headquarters TEL +81-(0)943-75-2195
FAX +81-(0)943-75-4396

Authorized Dealer